



Technical Application

LED Downlight

LUZ-DL65-3-10W

Introduction



Downlight DL65 is unique designed for European and Oceania market. Aluminum profile provides excellent thermal dissipation. Fire-rated PC diffuser adopts even light output. It is an ideal replacement for damp locations with IP54 waterproof structural design. Isolated driver solution both in dimmable and non-dimmable version, achieves great dimming compatibility with worldwide brand dimmers.

- Up to 70% energy saving compared to standard CFL
- Long lifetime of 40,000 hours
- Dimmable when using triac dimmer
- 90° wide beam angle
- Ø90mm cutout
- CCT: 3000K 4000K
5000K 5700K
- No UV/IR light
- Environment friendly, without Mercury or any other hazardous substances

Application notes

- IP54 for indoor use only
- Professional electrician for installation only
- Switch off before installation
- Do not touch when in use
- Keep away from hot steam and corrosive gas

Application Areas

It is designed for general lighting applications in office, supermarket, shop, school, hotel, etc. It is also widely used for public areas, such as stairway, lobby, reception, corridors etc.

Certificate



Product Information

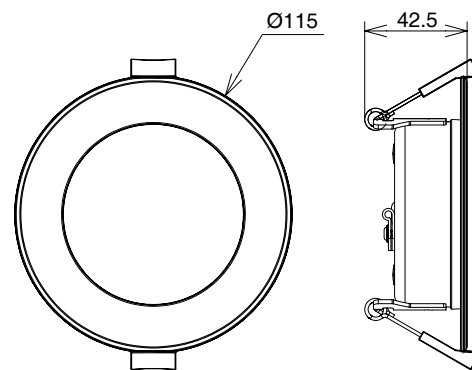

Technical Specifications

Model	Voltage	Power	Power Factor	Lumen (±5%)	Beam angle	CCT	Lifespan	CRI	Dimmable	Dimension
LUZ-DL65-3-10W	AC230V	10W	≥0.9	710	90°	3000K	40000h	≥80	No	Ø115*42.5mm cutout 90mm
LUZ-DL65-3-10W	AC230V	10W	≥0.9	760	90°	4000K	40000h	≥80	No	Ø115*42.5mm cutout 90mm
LUZ-DL65-3-10W	AC230V	10W	≥0.9	780	90°	5000K	40000h	≥80	No	Ø115*42.5mm cutout 90mm
LUZ-DL65-3-10W	AC230V	10W	≥0.9	800	90°	5700K	40000h	≥80	No	Ø115*42.5mm cutout 90mm
LUZ-DL65-3-10W-D	AC230V	10W	≥0.9	700	90°	3000K	40000h	≥80	Yes	Ø115*42.5mm cutout 90mm
LUZ-DL65-3-10W-D	AC230V	10W	≥0.9	740	90°	4000K	40000h	≥80	Yes	Ø115*42.5mm cutout 90mm
LUZ-DL65-3-10W-D	AC230V	10W	≥0.9	750	90°	5000K	40000h	≥80	Yes	Ø115*42.5mm cutout 90mm
LUZ-DL65-3-10W-D	AC230V	10W	≥0.9	780	90°	5700K	40000h	≥80	Yes	Ø115*42.5mm cutout 90mm

Driver data Sheet

Driver data	DIM	Non-dim
Input rated Voltage	AC230V	AC230V
Frequency	50HZ	50HZ
Input Voltage	AC200-240V	AC200-240V
Efficiency	≥78%	≥83%
Total load Wattage	10W±1W	10W±1W
Power Factor	≥0.9	≥0.9
Rated input current	≤0.06A	≤0.06A
Full load output Voltage	DC29-33V	DC29-33V
Rated output current	250mA	260mA
Output current range	250mA±5%	260mA±5%
Power tolerance	±5%	±5%
Current output tolerance	±5%	±5%
Dimming range	8%-100%	—
Dimmer	Triac dimmers	—
Short circuit protection	PASS	PASS
Over voltage protection	PASS	PASS
Over temperature protection	PASS	PASS
Withstand voltage	AC3750V	AC3750V

Fixture Compatibility

Rated Wattage	Electrical Classification	Ingress Protection	Operating Temp	Operating Humidity	Storage Temp
10W	II	IP54	-20°C~45°C	0~90%	-20°C~65°C

Spectral Distribution

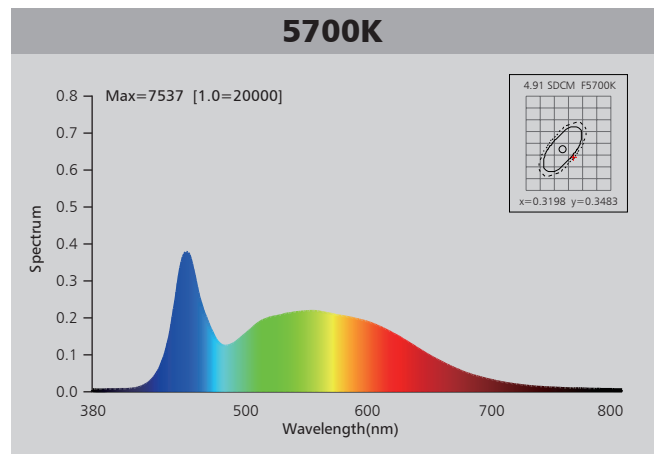
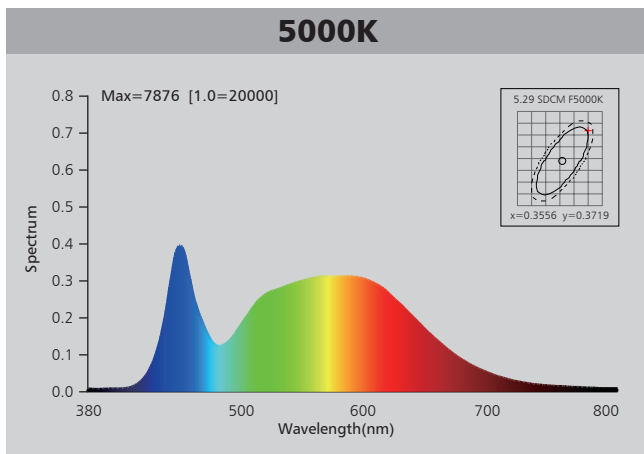
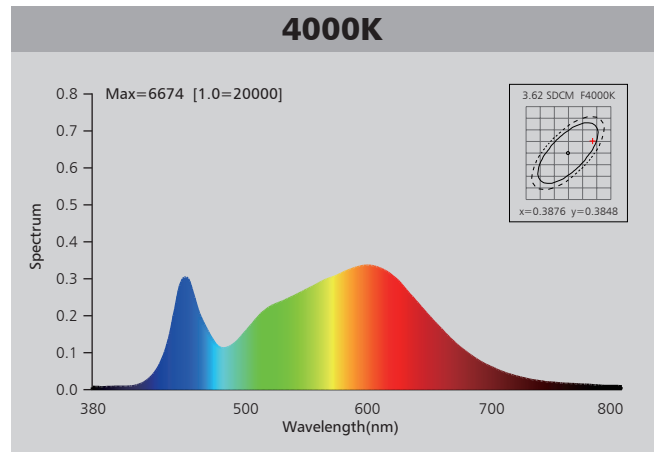
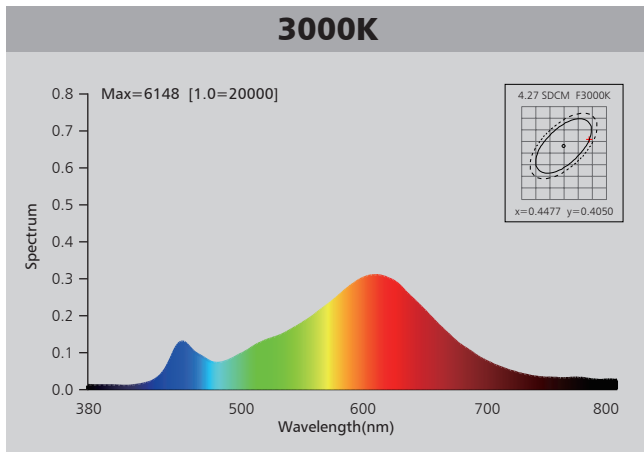

Photometric Diagram

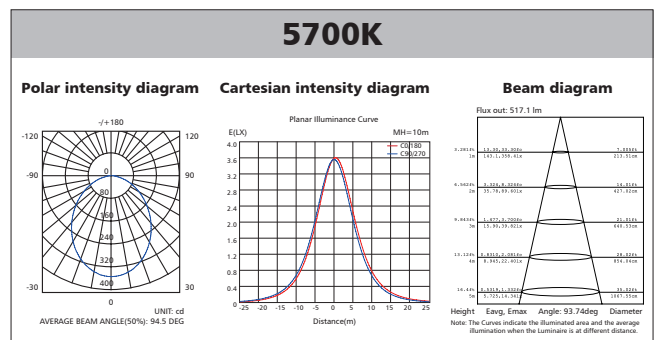
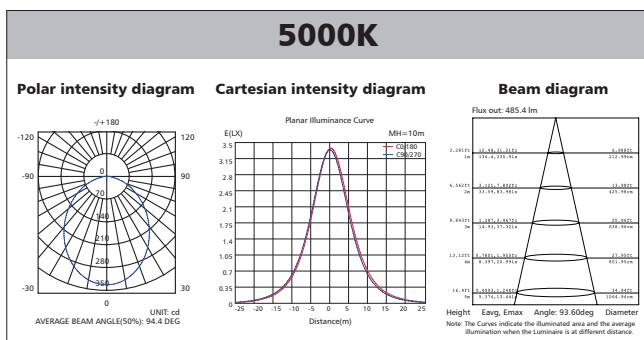
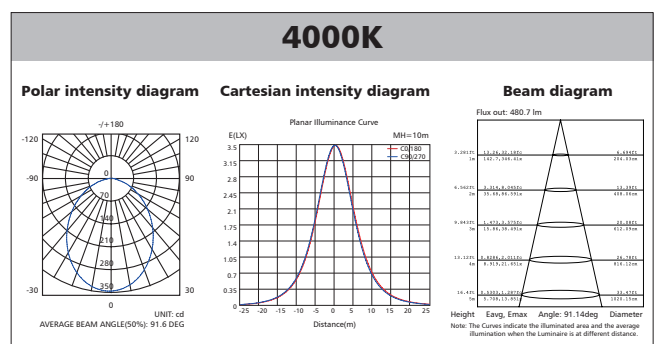
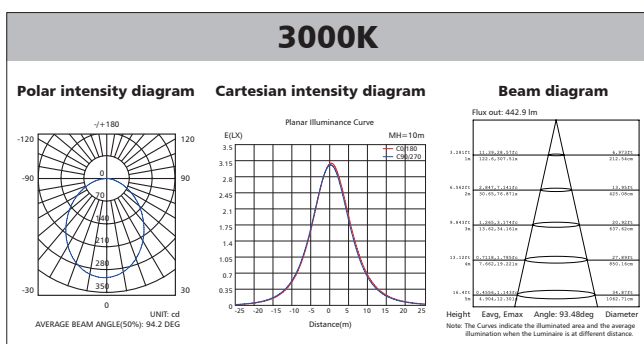

Polar Diagram Comparison

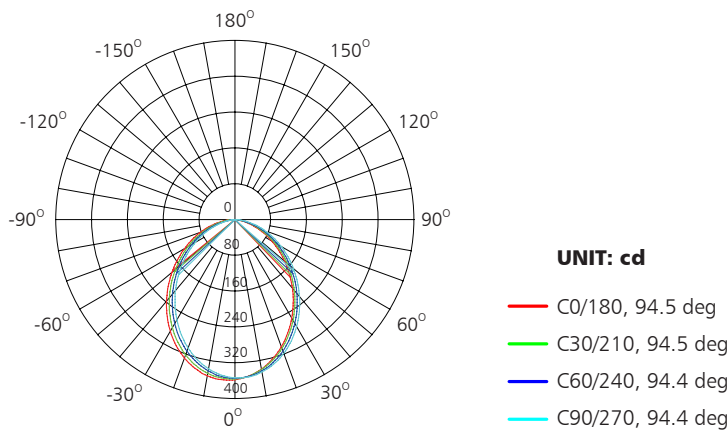

AVERAGE BEAM ANGLE (50%): 94.5DEG



Driver lifetime & LED light decay rate

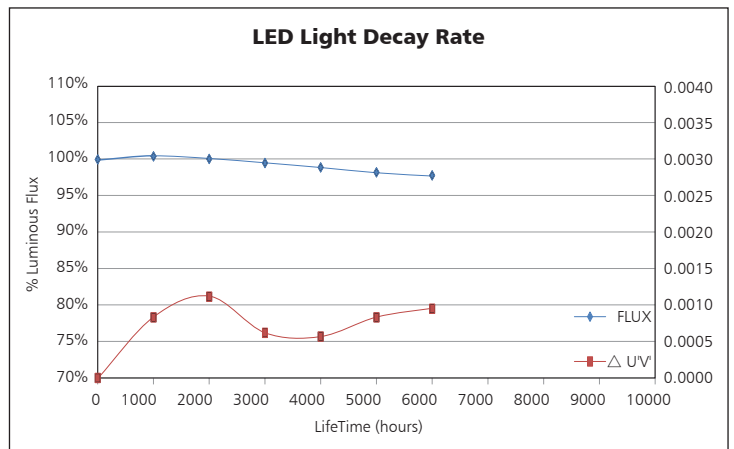
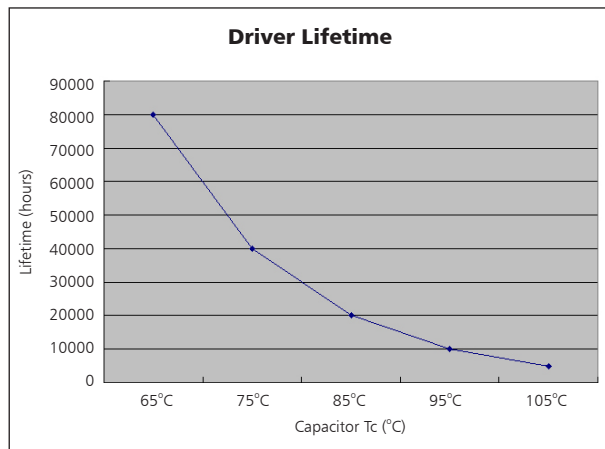

Temperature

- The testing is operated at 25°C
- The lifetime of capacitor, minimum of 5,000 hours if operated at 105°C, will be doubled whenever the temperature drops 10°C
- The highest withstand temperature of IC, MOS could be 120°C
- The highest withstand temperature of LED junction temperature is 150°C

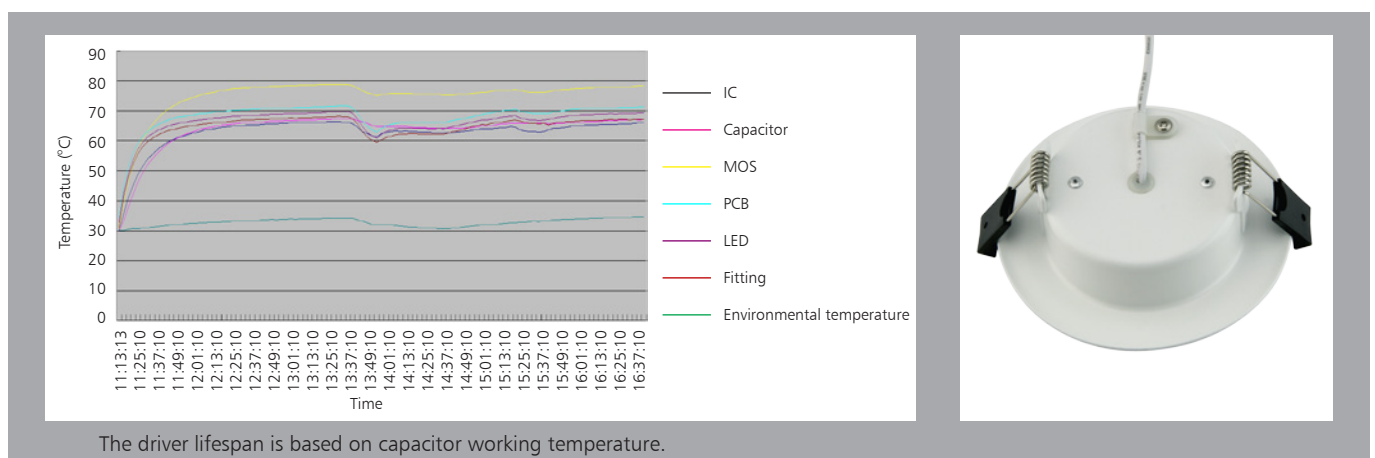

Installation

Install requirements	
A-gap above the fitting	25mm
B-gap to the building material	25mm
C-gap to the thermal insulation	25mm

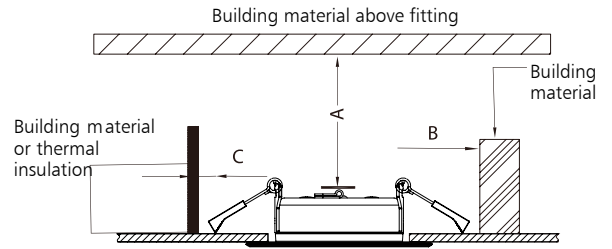

<p>Ceiling Opening</p>	<p>Connect Power supply</p>
<p>A. Hold back spring clips</p> <p>B. Push downlight into position</p>	<p>Spring Clips</p> <p>Ceiling</p>

Packaging Information

	SIZE(CM)	N.W/pc (KGS)	G.W.(KGS)	Q'TY(PCs)
Carton	52*40*33	0.26	11.5	36

	CTNS	Q'TY(PCs)	VOLUME(CBM)
20" standard container	402	14472	28
40" standard container	804	28944	56

