



Technical Application  
Guide for  
LED Panel Light  
PL3030-18W-AM  
PL3030-18W-AM-D

# Introduction



Super Slim square panel provided in full diameter, adopting SMD led chip. External driver comes with triac dim, it shares great popularity by perfect dimming range and great compatibility with worldwide dimmers. The ultra slim profile fits perfectly for all working places.

- Up to 80% energy saving compared to standard CFL
- Long lifetime of 40,000 hours
- Triac dim
- 120° wide beam angle
- 285\*285mm cutout
- CCT: 3000K 4000K  
5700K
- No UV/IR light
- Environment friendly, without Mercury or any other hazardous substances

## Application notes

- IP40 for indoor use only
- Professional electrician for installation only
- Switch off before installation
- Do not touch when in use
- Keep away from hot steam and corrosive gas

## Application Areas

Office & school lighting: office room, meeting room, class room etc.

Commercial lighting: shopping mall, super market, retailer shops etc.

Other situations: hospital, laboratory, dust-free workshop etc.



# Product Information

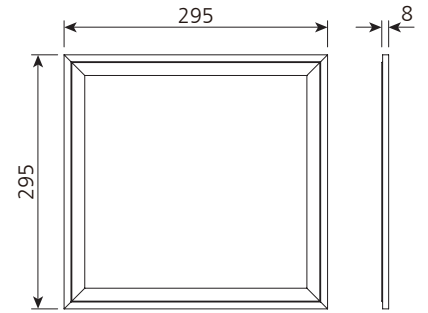

## Technical Specifications

Model	Voltage	Power	Power Factor	Lumen (±5%)	CCT	Beam angle	Lifespan	CRI	Dimmable	Dimension
PL3030-18W-AM	AC230V	18W	≥0.9	1530	3000K	120°	40,000h	≥80	No	295*295*8mm
				1620	4000K					
				1680	5700K					
PL3030-18W-AM-D	AC230V	18W	≥0.9	1360	3000K	120°	40,000h	≥80	YES	295*295*8mm
				1460	4000K					
				1550	5700K					

## Driver data Sheet

Driver data	DIM	Non-dim
Input rated Voltage	AC230V	AC230V
Frequency	50Hz	50Hz
Input Voltage	AC200-240V	AC200-240V
Efficiency	≥83%	≥85%
Total load Wattage	18W±1W	18W±1W
Power Factor	≥0.9	≥0.9
Rated input current	≤0.1A	≤0.1A
Full load output Voltage	DC35-38V	DC35-38V
Rated output current	430mA	440mA
Output current range	430mA±5%	440mA±5%
Power tolerance	±5%	±5%
Current output tolerance	±5%	±5%
Dimming range	8%-100%	
Dimmer	Triac dimmers	
Short circuit protection	PASS	PASS
Over voltage protection	PASS	PASS
Over temperature protection	PASS	PASS
Withstand voltage	AC3750V	AC3750V

## Fixture Compatibility

Rated Wattage	Electrical Classification	Ingress Protection	Operating Temp	Operating Humidity	Storage Temp
18W	II	IP40	-20°C~45°C	0~90%	-20°C~65°C

# Spectral Distribution

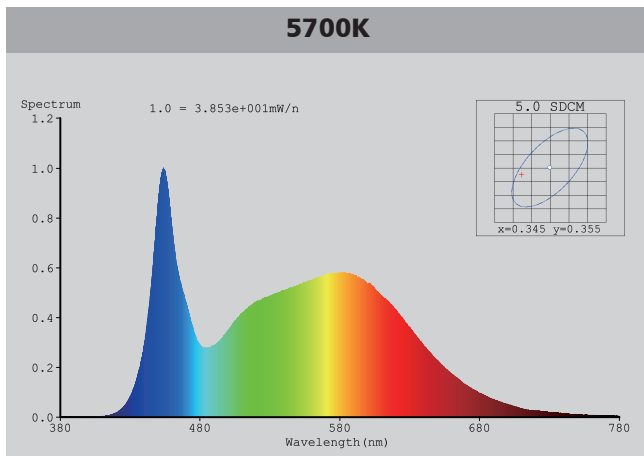
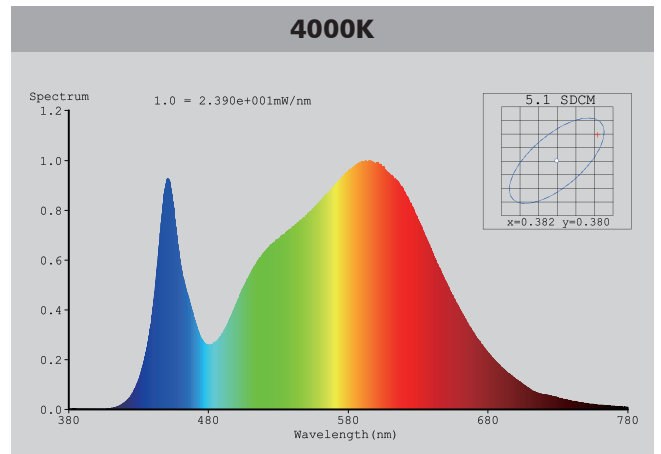
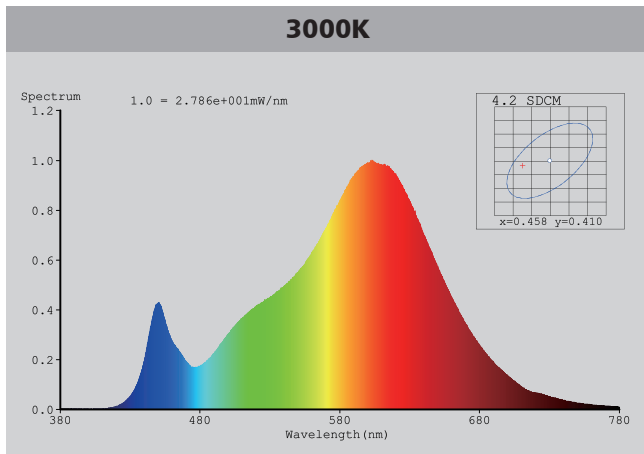

# Photometric Diagram

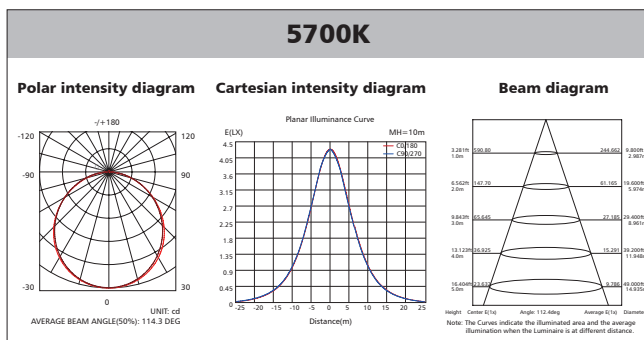
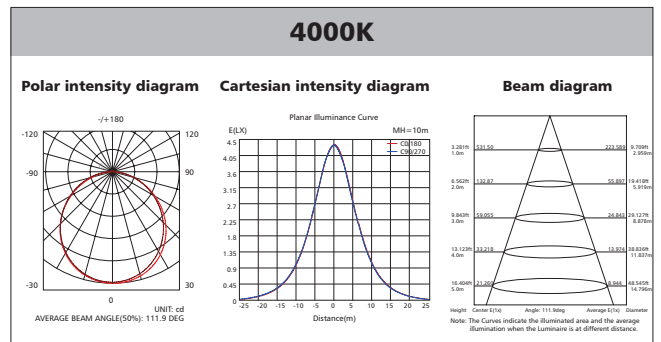
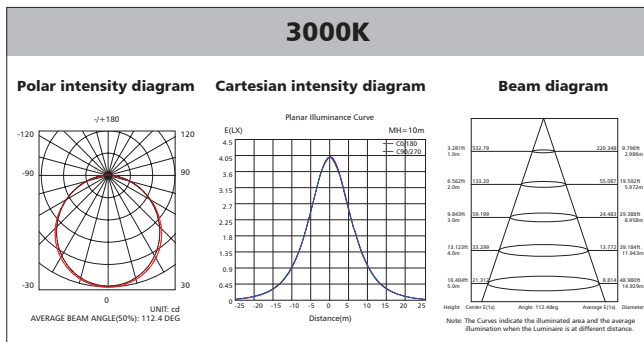

## Polar Diagram Comparison

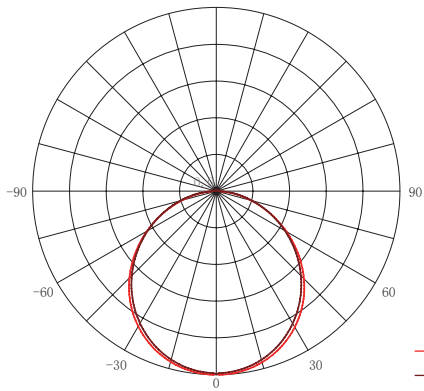

	C Plane	[50%MaxAng.]	[10%MaxAng.]
—	C90.0_270.0 :	112.4	162.5
—	C0.0_180.0 :	111.2	164.7

AVERAGE BEAM ANGLE (50%): 112.4DEG

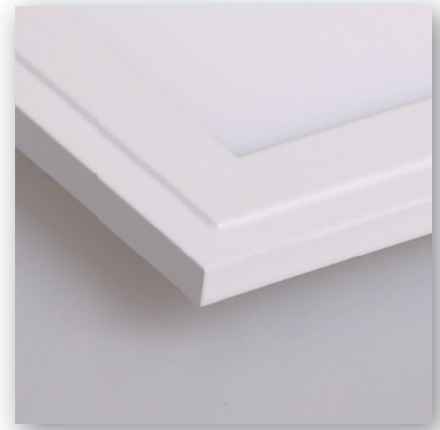

## Driver lifetime & LED light decay rate

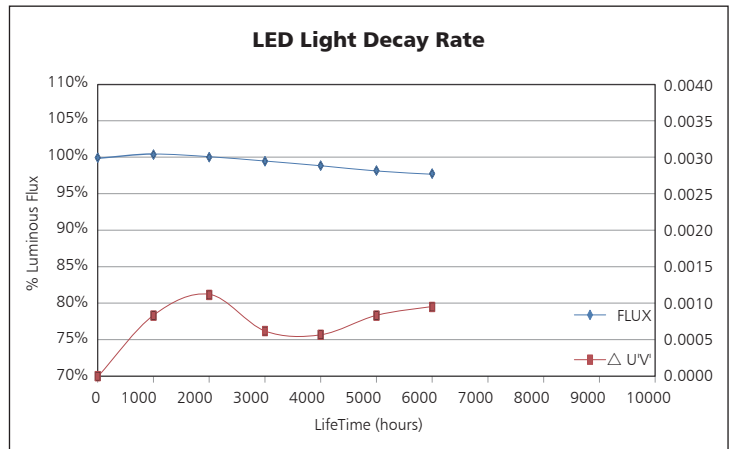
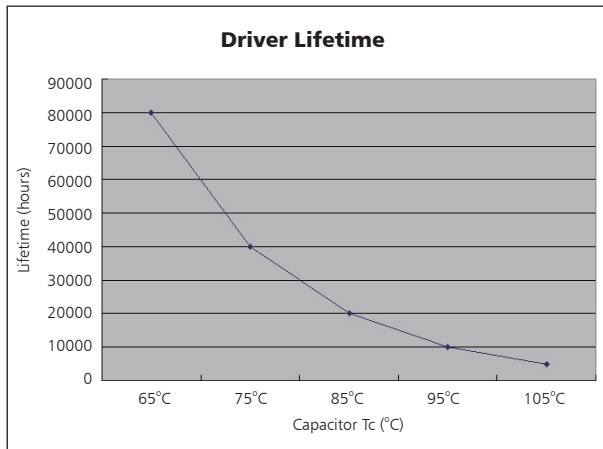

## Temperature

- The testing is operated at 25°C
- The lifetime of capacitor, minimum of 5,000 hours if operated at 105°C, will be doubled whenever the temperature drops 10°C
- The highest withstand temperature of IC, MOS could be 120°C
- The highest withstand temperature of LED junction temperature is 150°C

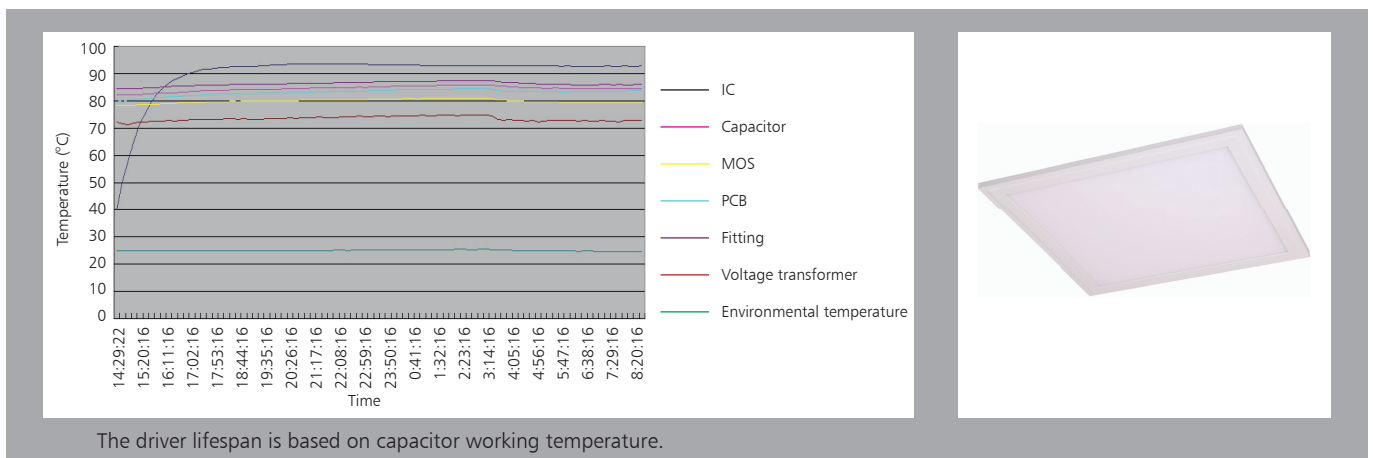

The driver lifespan is based on capacitor working temperature.

# Installation

**1. Recessed into ceiling**

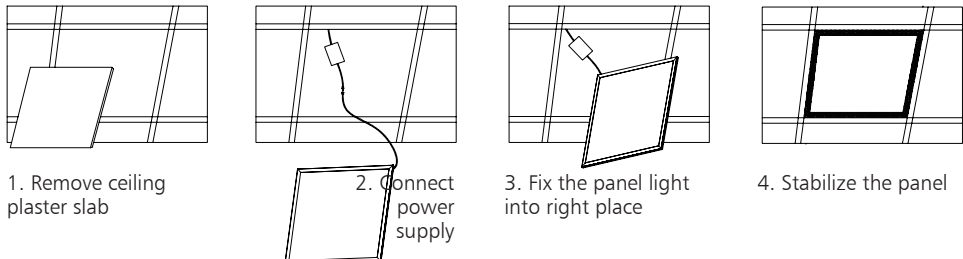

1. Remove ceiling plaster slab
2. Connect power supply
3. Fix the panel light into right place
4. Stabilize the panel

**2. Suspending**

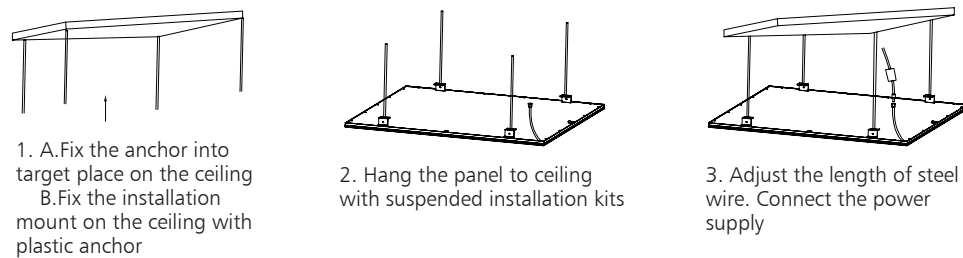

1. A. Fix the anchor into target place on the ceiling  
B. Fix the installation mount on the ceiling with plastic anchor
2. Hang the panel to ceiling with suspended installation kits
3. Adjust the length of steel wire. Connect the power supply

**3. Surface mounted**

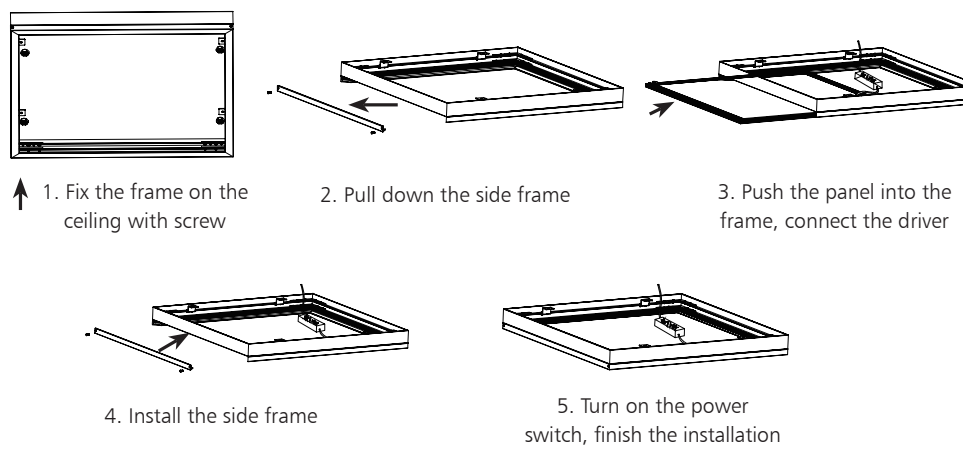

1. Fix the frame on the ceiling with screw
2. Pull down the side frame
3. Push the panel into the frame, connect the driver
4. Install the side frame
5. Turn on the power switch, finish the installation

# Packaging Information

	SIZE(CM)	N.W/pc (KGS)	G.W.(KGS)	Q'TY(PCs)
Carton	35.5*33*43.5	1.2	7	5

	CTNS	Q'TY(PCs)	VOLUME(CBM)
20" standard container	535	2675	28
40" standard container	1070	5350	56

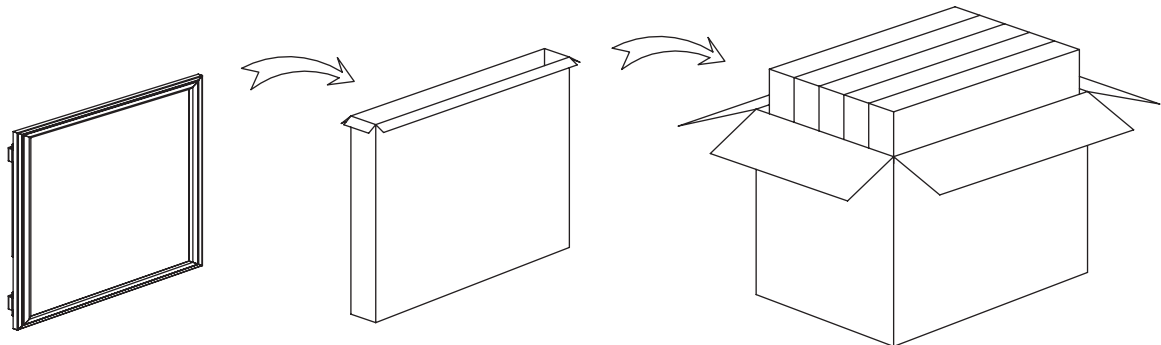

**Note:** If the diffused material LGP is constructed from quality PS material, while discoloration of LED panel is easily generated with exposure to sunlight/UV. In general installation area, places without sunlight/UV, PS is strong enough to support. However, sunlight/UV can cause discoloration, under this circumstance, we would recommend the use of LED panel made of PMMA material. Please note warranty does not cover discoloration of diffused material.