

luzon
lighting™

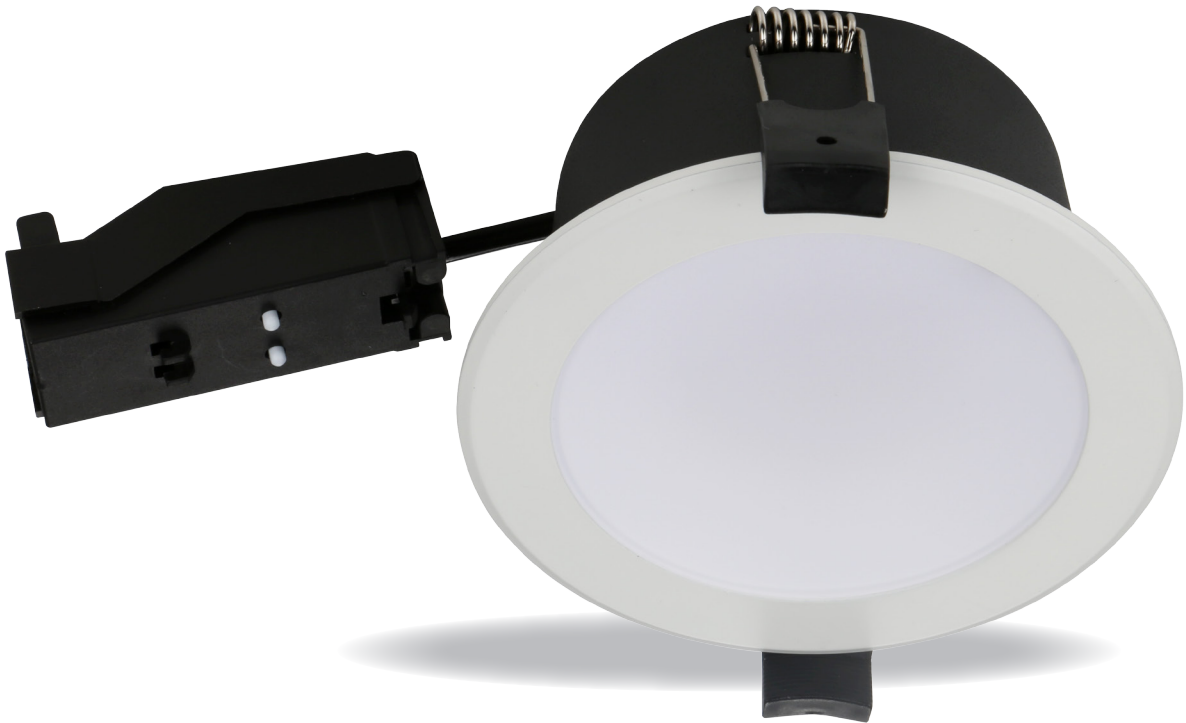

Technical Application Guide for
LED Downlight
DL128-3-10W-C3



Introduction

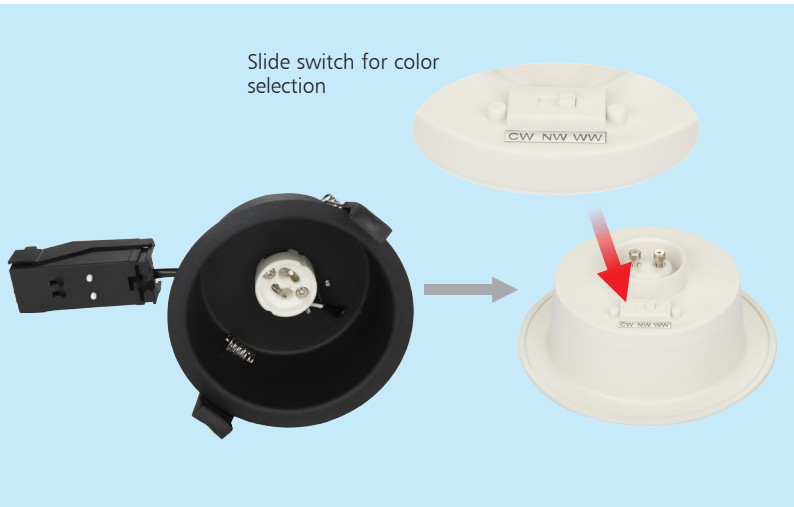

DL128 is a compact design detachable led downlight. The lighting module is designed as GU10 connection type no external driver required which makes maintenance and replacement much easier. The color temperature can be selected easily by adjusting the slide switch on the light module.

Features

1. Internal Driver
2. No external driver required which facilitates easy installation.
3. A perfect alternative to traditional ceiling mounted luminaries.

Application notes

- IP20 for indoor use
- Professional electrician for installation only
- Switch off before installation
- Do not touch when in use
- Keep away from hot steam and corrosive gas

Application Areas

It is designed for general lighting applications in office, supermarket, shop, school, hotel, etc. It is also widely used for public areas, such as stairway, lobby, reception, corridors etc.

Certificate

CE RoHS SAA



Product Information

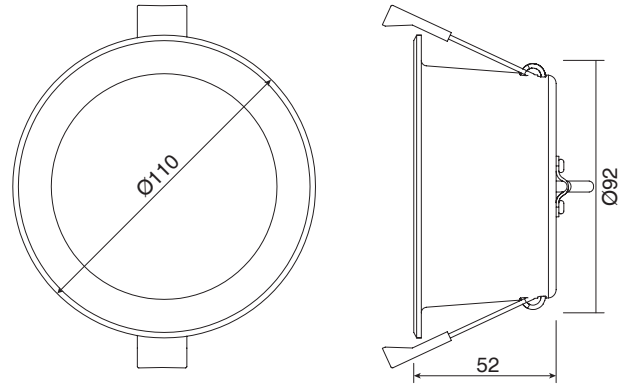

Technical Specifications

Model	Voltage	Power	Power Factor	Lumen (±5%)	CCT	Beam angle	Lifespan	CRI	Dimmable	Dimension
DL128-3-10W-C3	AC230V	10W	≥0.9	880	3000K	90°	50000h	≥80	No	Ø110*52mm cutout 90-95mm
				1000	4000K					
				920	5700K					

Driver data Sheet

Driver data	Non dim
Input rated Voltage	AC230V
Frequency	50Hz
Input Voltage	AC200-240V
Efficiency	≥75%
Total load Wattage	10W±1W
Power Factor	≥0.5
Rated input current	≤0.1A
Full load output Voltage	DC270V
Rated output current	30mA
Output current range	30mA±5%
Power tolerance	±5%
Current output tolerance	±5%
Short circuit protection	PASS
Over voltage protection	PASS
Over temperature protection	PASS
Withstand voltage	—

Fixture Compatibility

Rated Wattage	Electrical Classification	Ingress Protection	Operating Temp	Operating Humidity	Storage Temp
10W	II	IP20	-20°C~45°C	0~90%	-20°C~65°C

Spectral Distribution

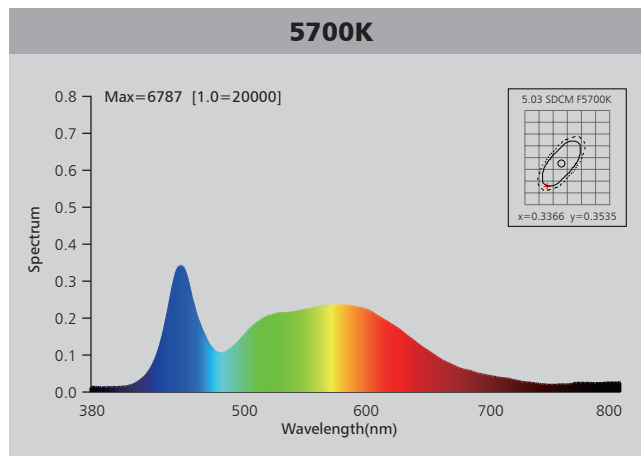
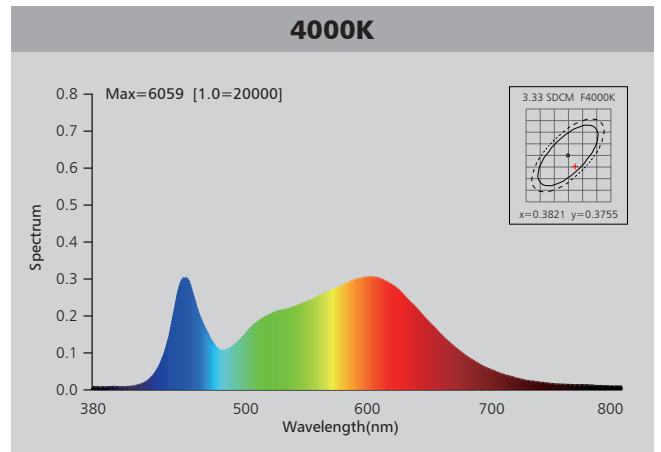
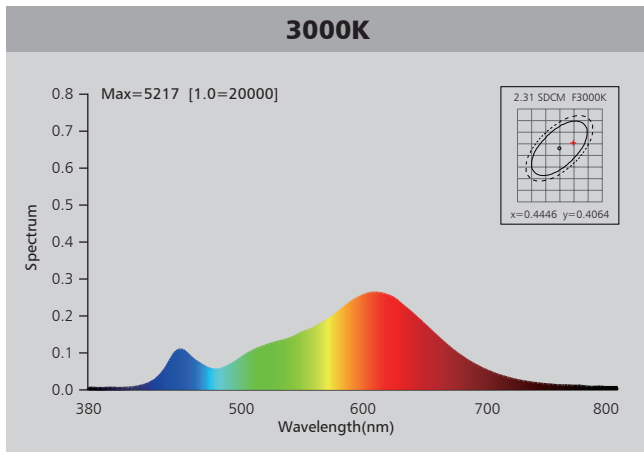

Photometric Diagram

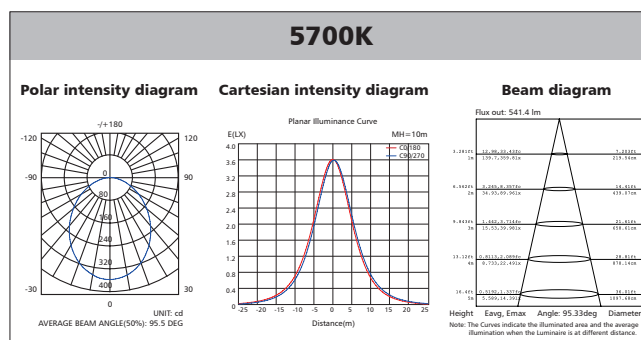
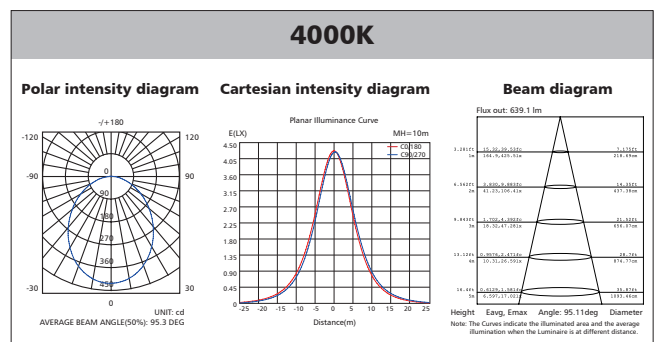
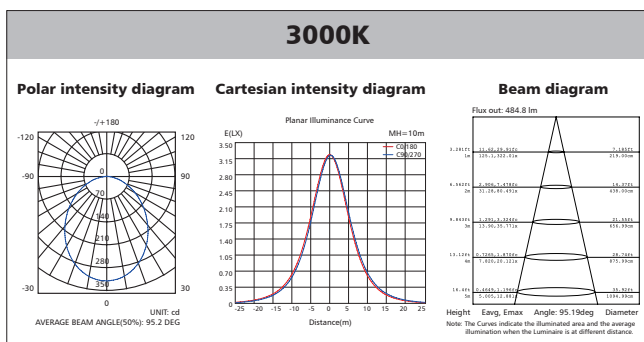

Polar Diagram Comparison

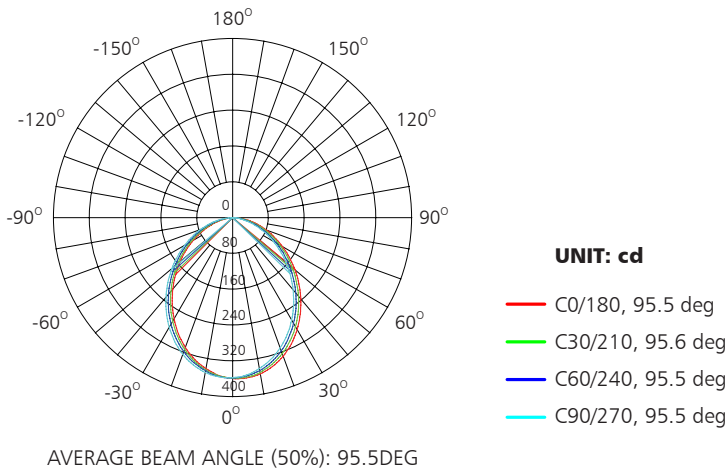

Driver lifetime & LED light decay rate

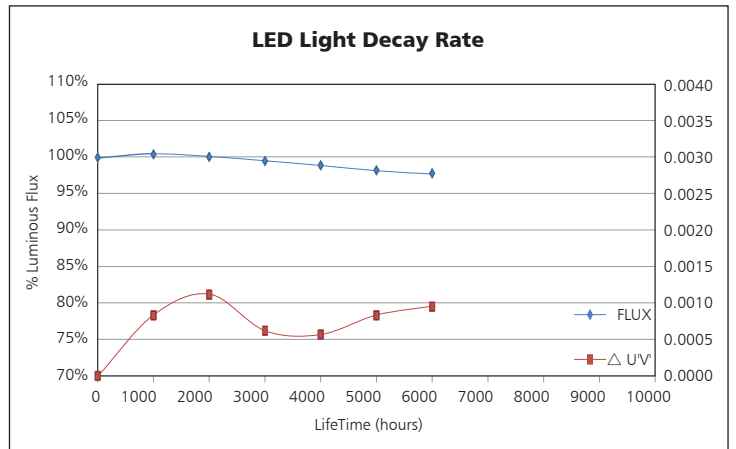
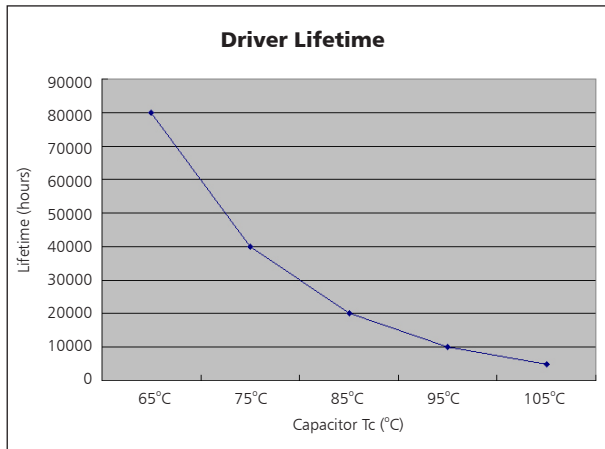

Temperature

- The testing is operated at 25°C
- The lifetime of capacitor, minimum of 5,000 hours if operated at 105°C, will be doubled whenever the temperature drops 10°C
- The highest withstand temperature of IC, MOS could be 120°C
- The highest withstand temperature of LED junction temperature is 150°C

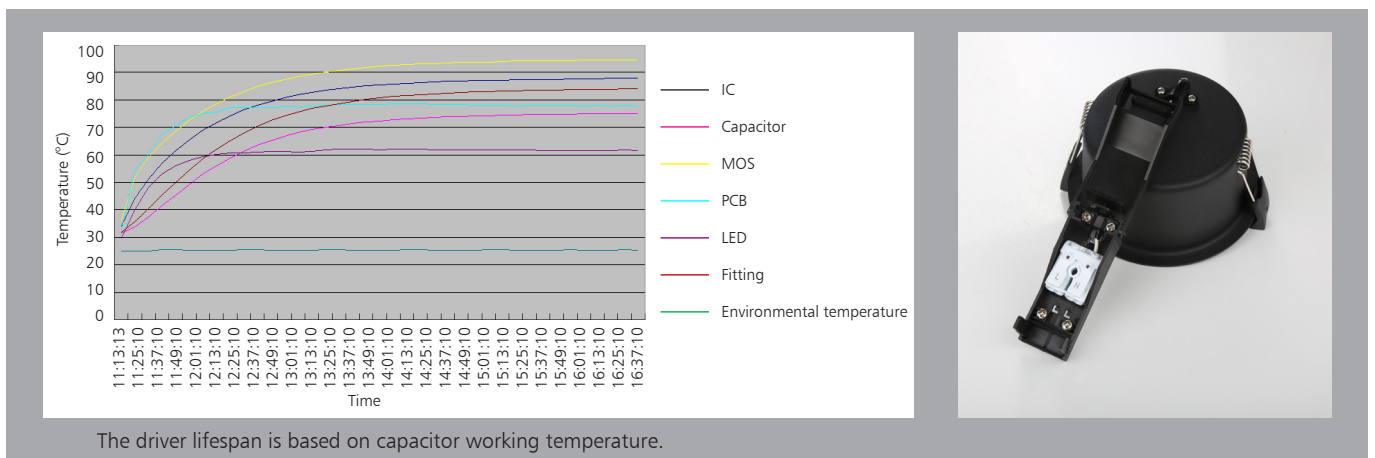

Installation

WARNING

1. Switch off before installation.
2. Switch on only after complete installation and examination of the circuit.
3. Professional electrician for installation and maintenance only.

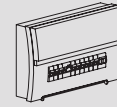

Turn Off power supply before starting any installation. Read instructions & check you have all the tools & accessories to complete the installation correctly.

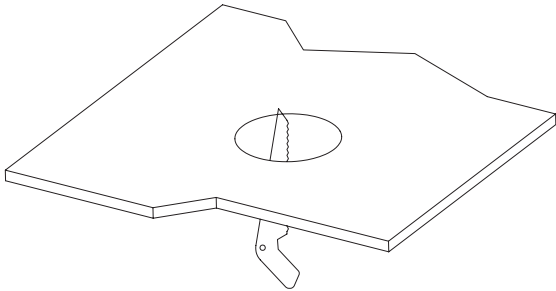
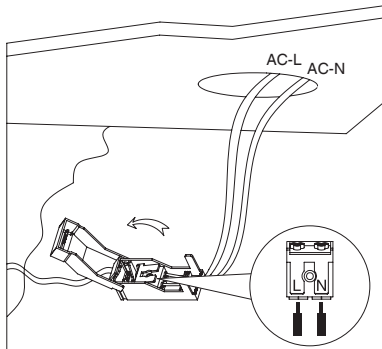
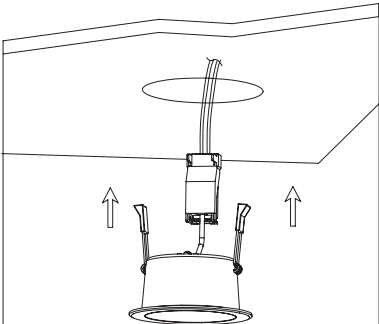
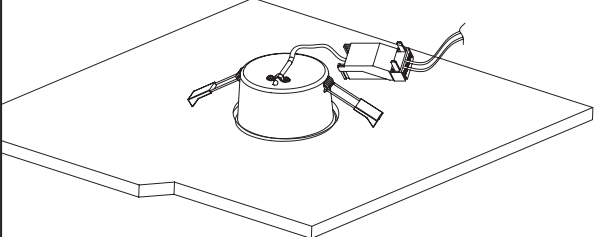
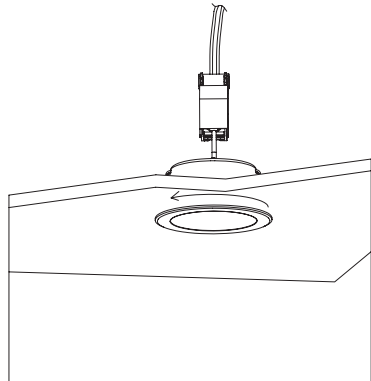
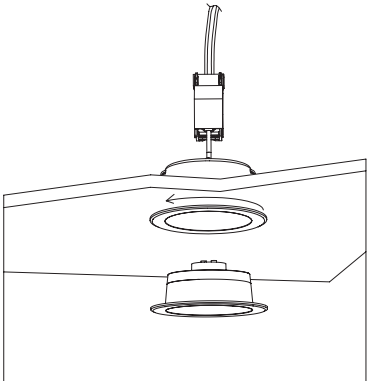
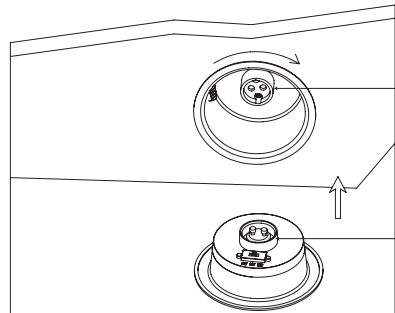
 <p>1. Open a hole according to the cutout size of the lamp.</p>	 <p>2. Open the terminal block cover, Feed the main AC wire L-N respectively, then fix the cover back.</p>
 <p>3. Hold back the spring clips, push the down light into the ceiling(make sure the size can be matched first).</p>	 <p>4. Fix the down light tightly, turn on the power.</p>
	 <p>5. Please make sure the power is off before start the steps below: Remove the light module when replace the lamp (or change color), the module can be rotated easily in counterclockwise direction.</p>
	<p>6. Match the GU10 holder with the base, rotate it in clockwise direction. Installation complete.</p>

Packaging Information

	SIZE(CM)	N.W/pc (KGS)	G.W.(KGS)	Q'TY(PCS)
Carton	52*39.5*22	0.31	12	24

	CTNS	Q'TY(PCS)	VOLUME(CBM)
20" standard container	600	14400	28
40" standard container	1200	28800	56

