



Technical Application Guide for
LED Downlight
DL113-4-20W

Introduction



COB downlight is unique designed with reflector and COB high power LED chip. ADC12 Aluminum profile provides excellent thermal dissipation. Short heatsink designed for any ceiling installations. Isolated driver solution both in dimmable and non-dimmable version achieves great dimming compatibility with worldwide brand dimmers.

- Up to 70% energy saving compared to standard CFL
- Long lifetime of 50,000 hours
- Triac dim, 0-10V dim, DALI dim
- 60° wide beam angle
- 135-140mm cutout
- CCT: 2700K 3000K 4000K 5000K
- No UV/IR light
- Environment friendly, without Mercury or any other hazardous substances
- External Drive

Application notes

- IP20 for indoor use only
- Professional electrician for installation only
- Switch off before installation
- Do not touch when in use
- Keep away from hot steam and corrosive gas

Application Areas

It is designed for general lighting applications in office, supermarket, shop, school, hotel, etc. It is also widely used for public areas, such as stairway, lobby, reception, corridors etc.

Certificate

CE RoHS



Product Information

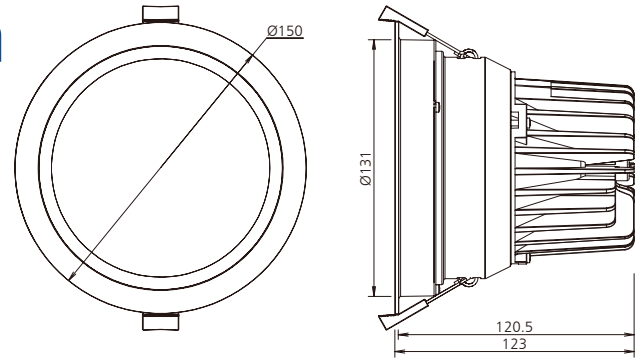

Technical Specifications

Model	Voltage	Power	Power Factor	Lumen (±5%)	Beam angle	CCT	Lifespan	CRI	Dimmable	Dimension
DL113-4-20W	AC230V	20W	≥0.9	2090	60°	2700K	50000h	≥80	No	Ø150*123mm cutout 135-140mm
DL113-4-20W	AC230V	20W	≥0.9	2190	60°	3000K	50000h	≥80	No	Ø150*123mm cutout 135-140mm
DL113-4-20W	AC230V	20W	≥0.9	2280	60°	4000K	50000h	≥80	No	Ø150*123mm cutout 135-140mm
DL113-4-20W	AC230V	20W	≥0.9	2160	60°	5000K	50000h	≥80	No	Ø150*123mm cutout 135-140mm
DL113-4-20W-D	AC230V	20W	≥0.9	1970	60°	2700K	50000h	≥80	Yes	Ø150*123mm cutout 135-140mm
DL113-4-20W-D	AC230V	20W	≥0.9	2090	60°	3000K	50000h	≥80	Yes	Ø150*123mm cutout 135-140mm
DL113-4-20W-D	AC230V	20W	≥0.9	2200	60°	4000K	50000h	≥80	Yes	Ø150*123mm cutout 135-140mm
DL113-4-20W-D	AC230V	20W	≥0.9	2120	60°	5000K	50000h	≥80	Yes	Ø150*123mm cutout 135-140mm

Driver data Sheet

Driver data	DIM	Non dim
Input rated Voltage	AC230V	AC230V
Frequency	50Hz	50Hz
Input Voltage	AC200-240V	AC220-240V
Efficiency	≥85%	≥85%
Total load Wattage	20W±5%	20W±5%
Power Factor	≥0.9	≥0.9
Rated input current	≤0.12A	≤0.12A
Full load output Voltage	DC23-40V	DC27-42V
Rated output current	480mA	500mA
Output current range	480mA±5%	500mA±5%
Power tolerance	±5%	±5%
Current output tolerance	±5%	±5%
Dimming range	8%-100%	—
Dimmer	Triac dimmers	—
Short circuit protection	PASS	PASS
Over voltage protection	PASS	PASS
Over temperature protection	PASS	PASS
THD	≤20%	≤10%
Withstand voltage	AC3750V	AC3750V

Fixture Compatibility

Rated Wattage	Electrical Classification	Ingress Protection	Operating Temp	Operating Humidity	Storage Temp
20W	II	IP20	-20°C~45°C	0~90%	-20°C~65°C

Spectral Distribution

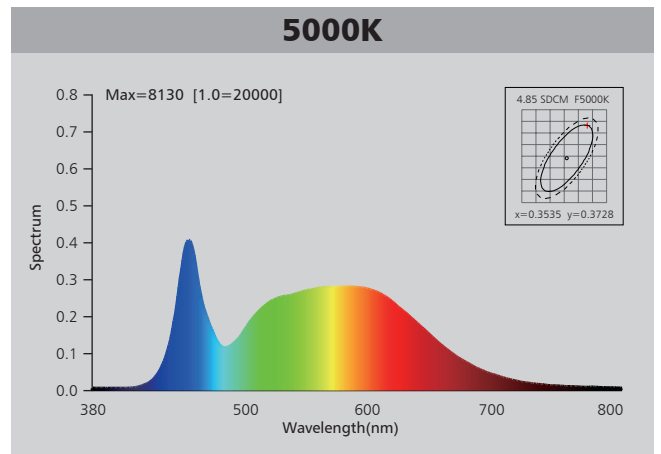
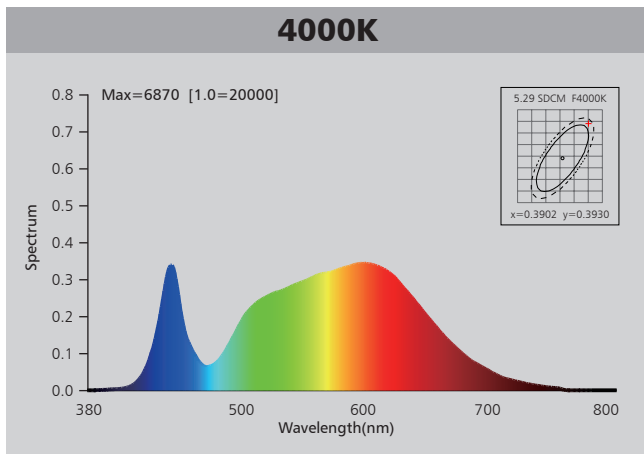
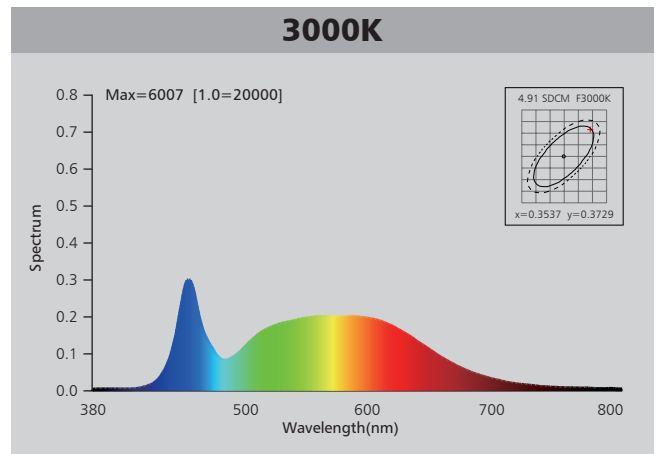
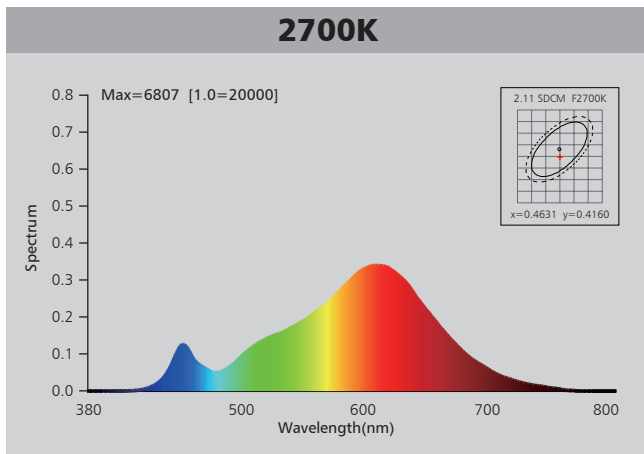

Photometric Diagram

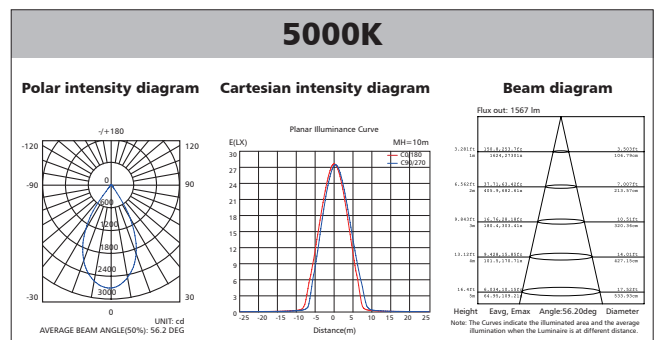
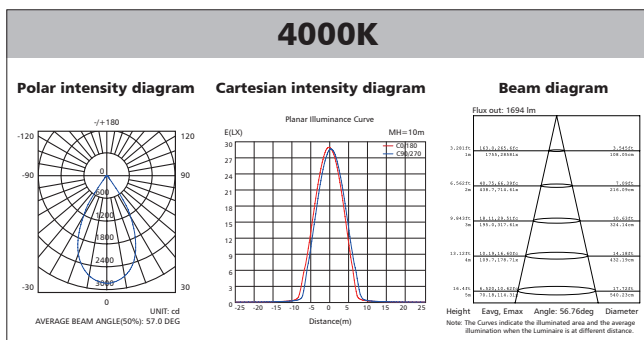
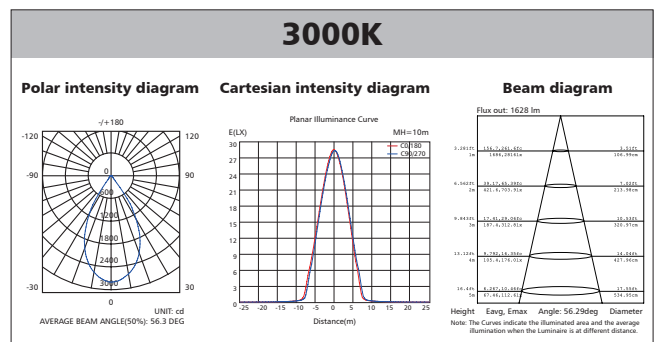
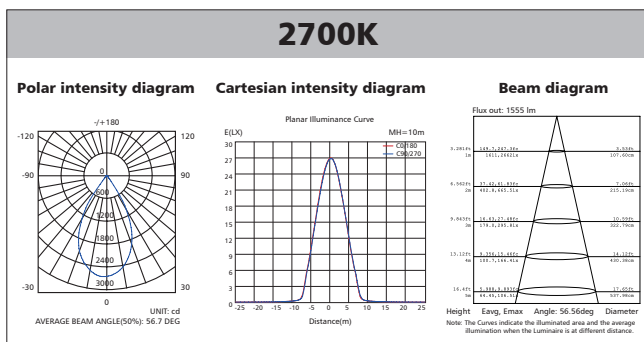

Polar Diagram Comparison

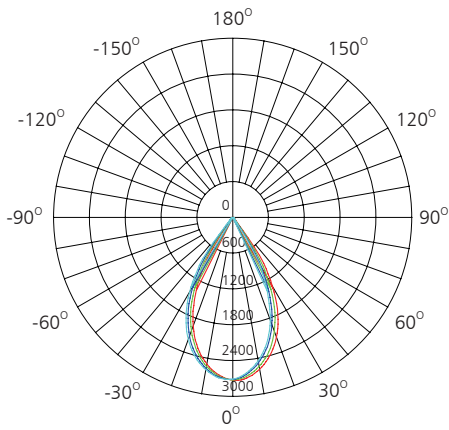

UNIT: cd

- C0/180, 56.3 deg
- C30/210, 56.3 deg
- C60/240, 56.1 deg
- C90/270, 56.3 deg

AVERAGE BEAM ANGLE (50%): 56.2DEG



Driver lifetime & LED light decay rate

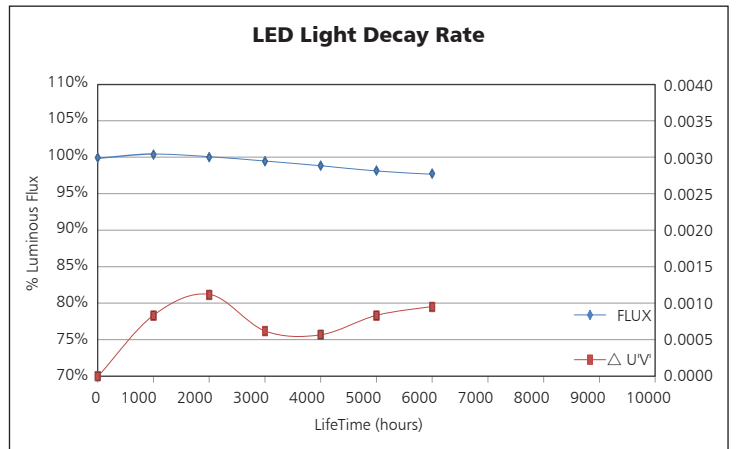
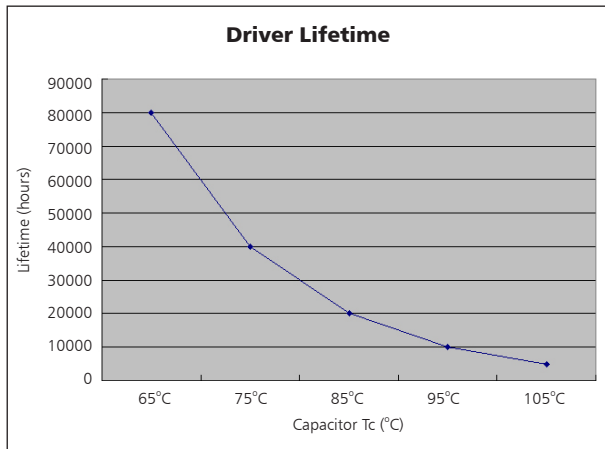

Temperature

- The testing is operated at 25°C
- The lifetime of capacitor, minimum of 5,000 hours if operated at 105°C, will be doubled whenever the temperature drops 10°C
- The highest withstand temperature of IC, MOS could be 120°C
- The highest withstand temperature of LED junction temperature is 150°C

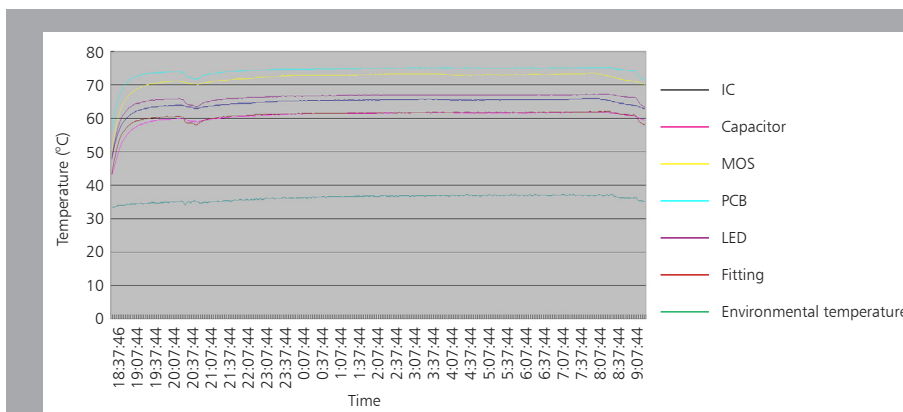

The driver lifespan is based on capacitor working temperature.

Installation

Install requirements	
A-gap above the fitting	25mm
B-gap to the building material	25mm
C-gap to the thermal insulation	25mm

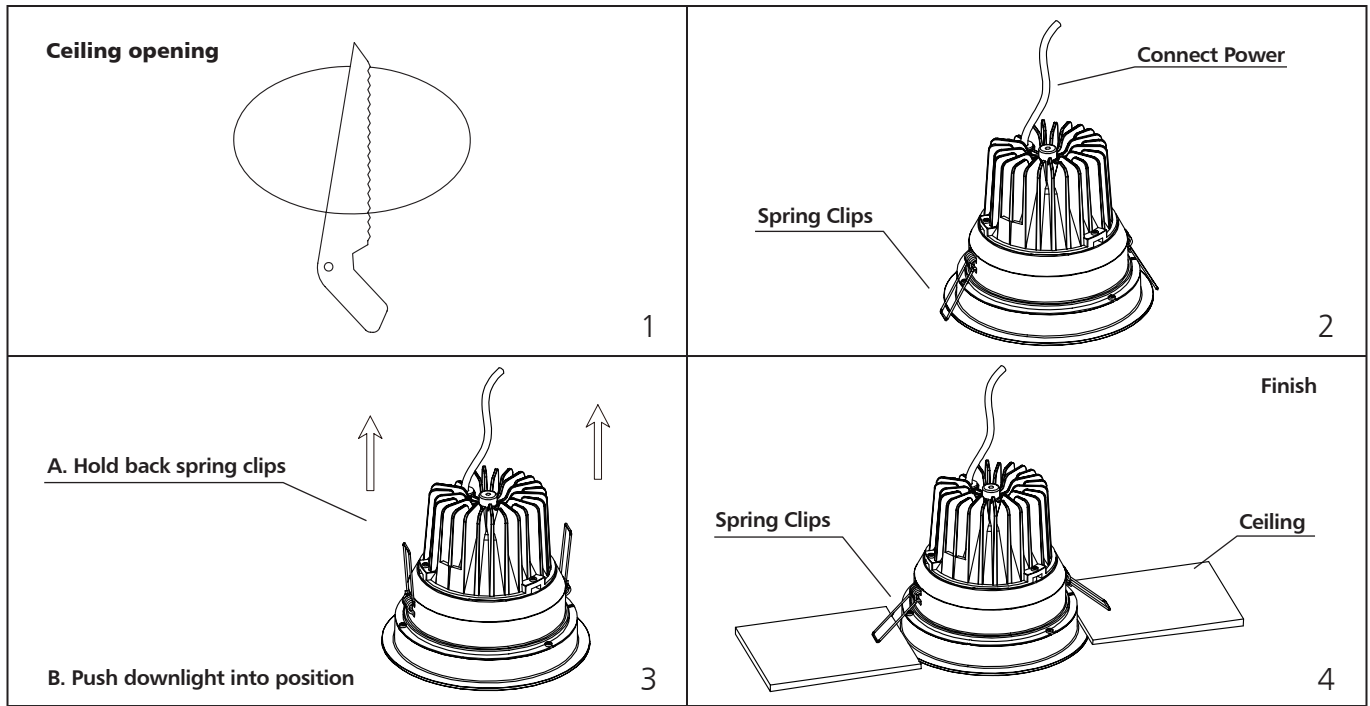
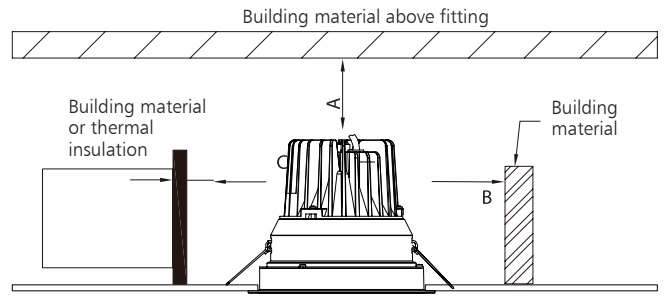

Packaging Information

	SIZE(CM)	N.W/pc (KGS)	G.W.(KGS)	Q'TY(PCS)
Carton	50*34*30	0.85	13.3	12

	CTNS	Q'TY(PCS)	VOLUME(CBM)
20" standard container	538	6456	28
40" standard container	1076	12912	56

