



# Technical Application Guide for LED Track Light

TL25B-25W

# Introduction



LED Track light adopts CREE LEDs with excellent color rendering index to increase the color fidelity of the target illuminated object. Providing excellent heat dissipation, even light output without glare & dark spot. Adjustable lighting orientation with 350 degree in horizontal direction and 90 in vertical direction provided. 1-circuit adapter, 3-circuit adapter offered for wide choice.

- Up to 70% energy saving compared to standard CFL
- Long lifetime of 50,000 hours
- 15°/24°/36° beam angle
- CCT: 2700K 3000K  
4000K 5000K
- No UV/IR light
- Environment friendly, without Mercury or any other hazardous substances

## Application notes

- IP20 for indoor use only
- Professional electrician for installation only
- Switch off before installation
- Do not touch when in use
- Keep away from hot steam and corrosive gas

## Application Areas

It is suitable for supermarket, specialty store, show window, exhibition hall; focus lighting, decorative and background lighting, where attention is focused on subjects to emphasize special visual points.

## Certificate

**CE** **RoHS** **SAA**



# Product Information

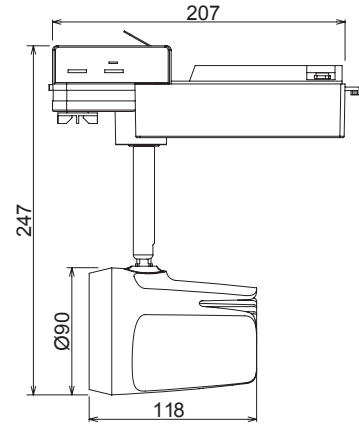

## Technical Specifications

Model	Voltage	Power	Power Factor	Lumen (±5%)	Beam angle	CCT	Lifespan	CRI	Dimmable	Dimension
TL25B-25W	AC230V	25W	≥0.9	2200	15°/24°/36°	2700K	50,000h	≥80	No	207*90*247mm
TL25B-25W	AC230V	25W	≥0.9	2375	15°/24°/36°	3000K	50,000h	≥80	No	207*90*247mm
TL25B-25W	AC230V	25W	≥0.9	2450	15°/24°/36°	4000K	50,000h	≥80	No	207*90*247mm
TL25B-25W	AC230V	25W	≥0.9	2600	15°/24°/36°	5000K	50,000h	≥80	No	207*90*247mm

## Driver data Sheet

Driver data	Non dim
Input rated Voltage	AC230V
Frequency	50/60Hz
Input Voltage	AC220-240V
Efficiency	≥87%
Total load Wattage	25W±5%
Power Factor	≥0.9
Rated input current	≤0.15A
Full load output Voltage	DC27-40V
Rated output current	580mA
Output current range	580mA±5%
Power tolerance	±5%
Current output tolerance	±5%
Short circuit protection	PASS
Over voltage protection	PASS
Over temperature protection	PASS
THD	≤18%
Withstand voltage	AC1500V

## Fixture Compatibility

Rated Wattage	Electrical Classification	Ingress Protection	Operating Temp	Operating Humidity	Storage Temp
25W	I	IP20	-20°C~45°C	0~90%	-20°C~65°C

# Spectral Distribution

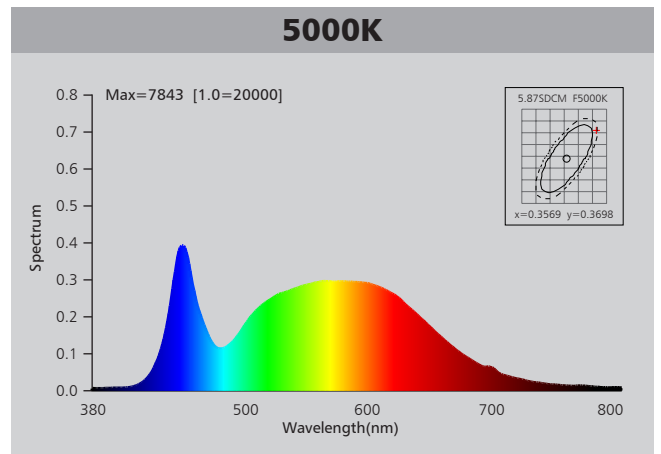
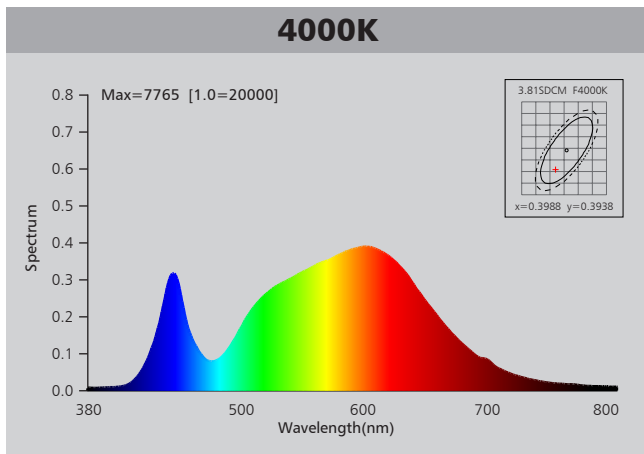
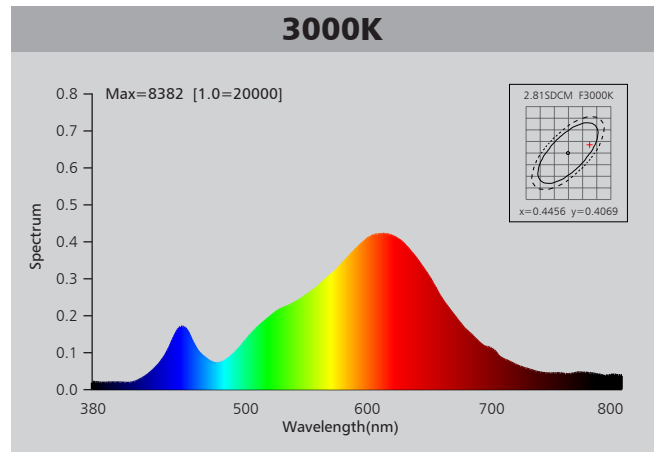
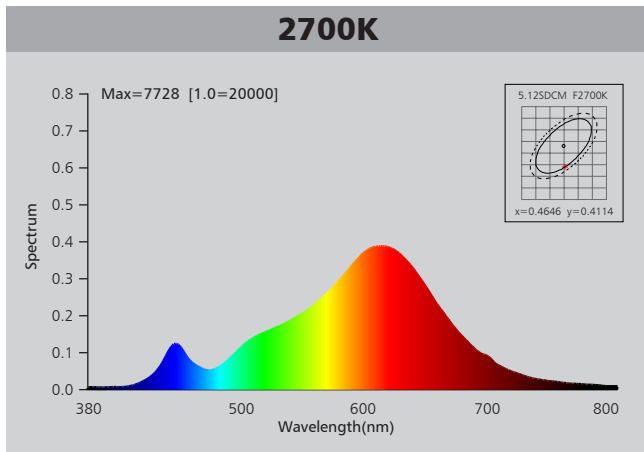

# Photometric Diagram

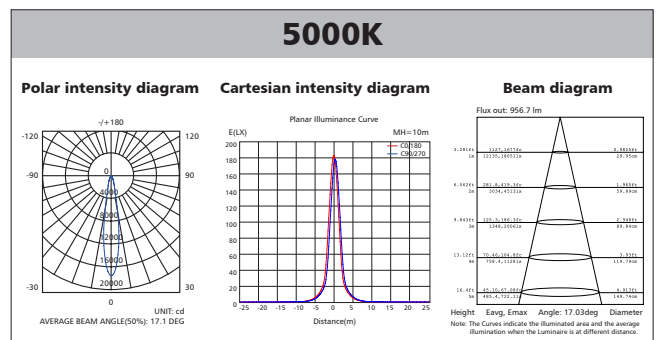
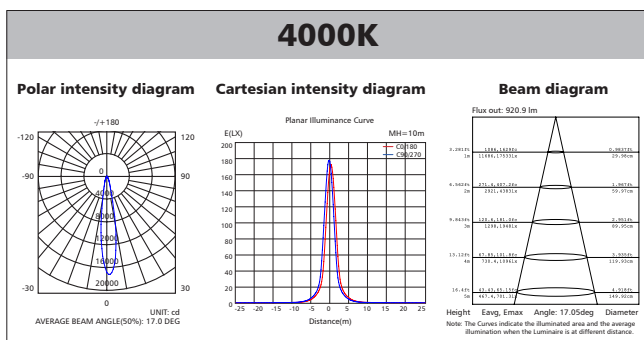
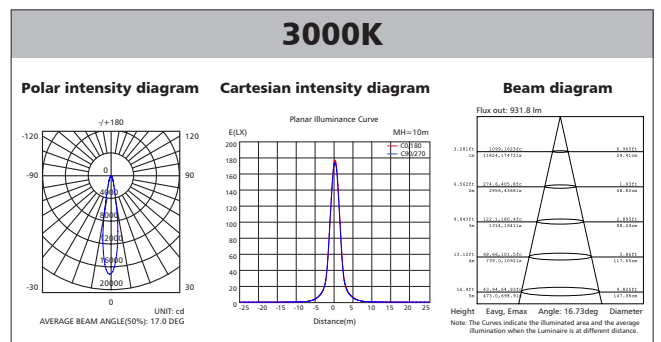
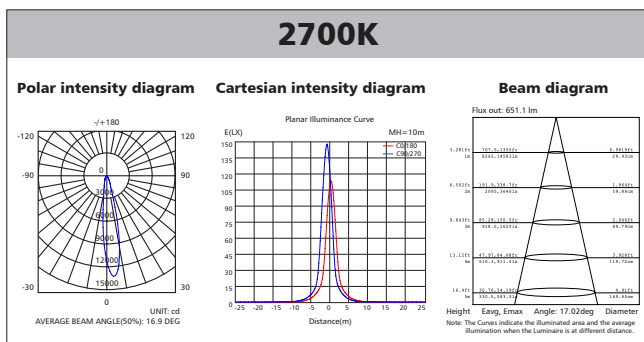

## Polar Diagram Comparison

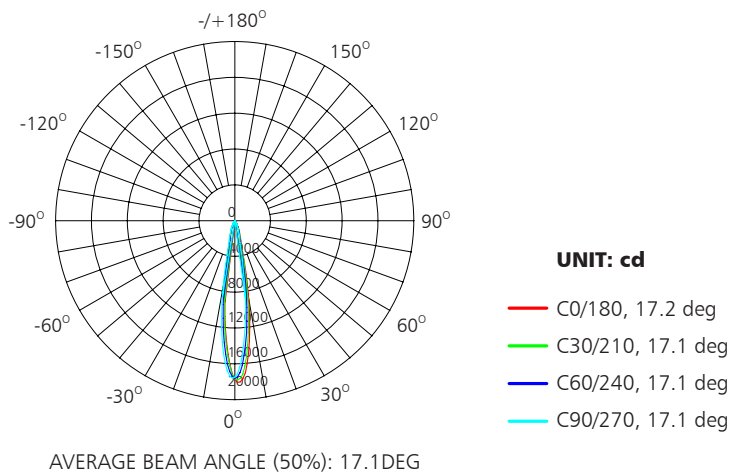

## Driver lifetime & LED light decay rate

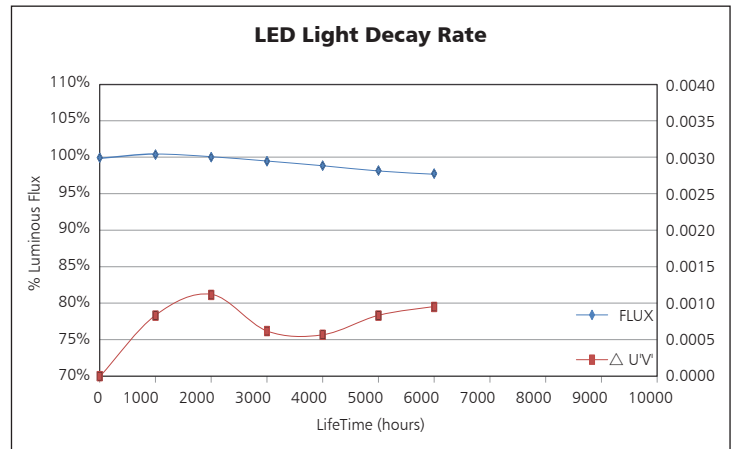
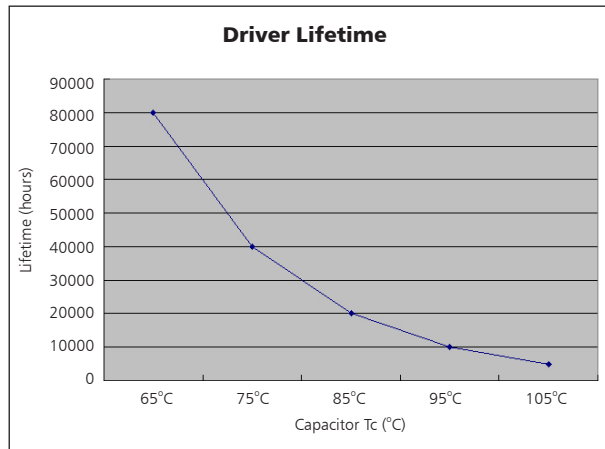

## Temperature

- The testing is operated at 25°C
- The lifetime of capacitor, minimum of 5,000 hours if operated at 105°C, will be doubled whenever the temperature drops 10°C.
- The highest withstand temperature of IC, MOS could be 120°C
- The highest withstand temperature of LED junction temperature is 150°C

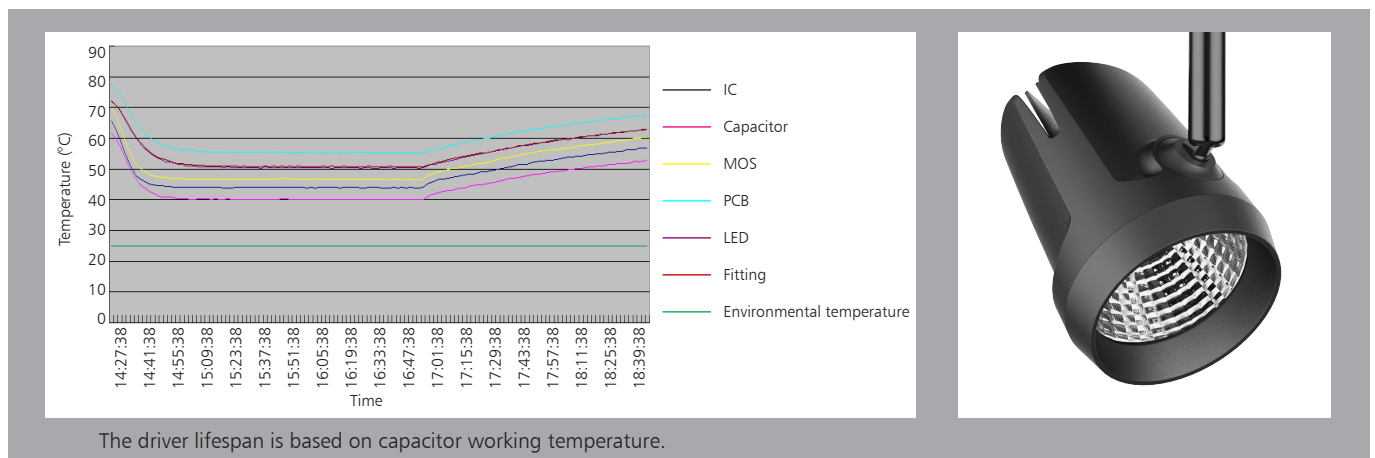

## Installation Procedure

### WARNING

1. Switch off before installation.
2. Switch on only after complete installation and examination of the circuit.
3. Professional electrician for installation and maintenance only.

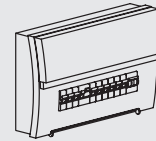

### Step 1

Turn Off power supply before starting any installation. Read instructions & check you have all the tools & accessories to complete the installation correctly.

### Step 2

Prior to locating Adaptor into Track Section make sure it is set in the 'OFF' position & 'Locking Lever' is set in the position shown.

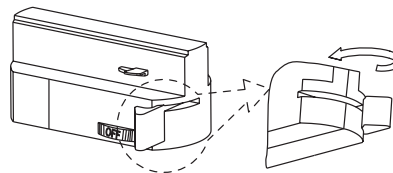

2-wires, 3-wires adaptor

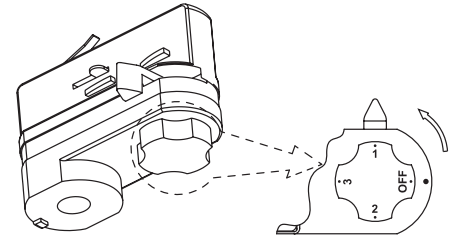

4-wires adaptor

### Step 3

Locate Track Adaptor into Track Section (1) & lock into position by turning 'Locking Lever' 90°(2)

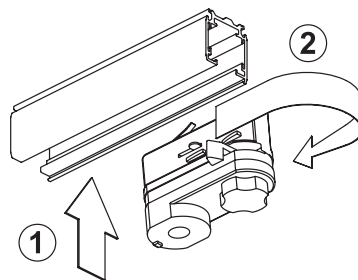

Track Section

Track Adaptor shown locked into Track Section

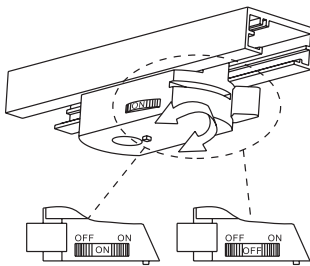

2-wires, 3-wires control luminaires in same circuit by ON/OFF switch.

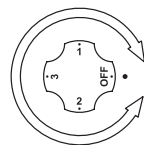

4-wires Turn clockwise or anti-clockwise.

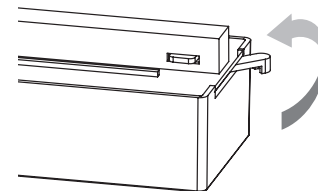

Lock the driver box into track section by turning "Locking Lever" clockwise.

## Packaging Information

	SIZE(CM)	N.W/pc (KGS)	G.W.(KGS)	Q'TY(PCS)
Carton	53*49*44.5	0.75	11.2	12

	CTNS	Q'TY(PCS)	VOLUME(CBM)
20" standard container	240	2880	28
40" standard container	480	5760	56

