

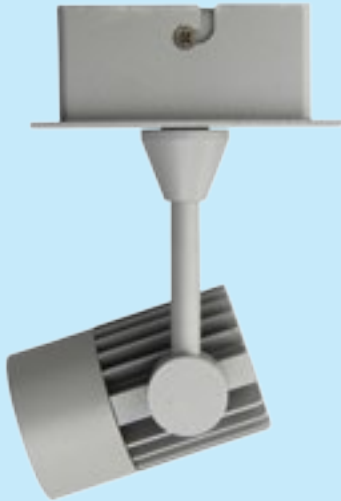

Technical Application Guide for LED track light

TL04-10W-B

Introduction



LED track light adopts high efficient reflector and COB LED chip. It is designed with advanced light distribution technology without glare, maximum utilization of light output. Dimmable available for wide choice; surface mounted and embedded installation provided for all possible installation situations.

- Up to 70% energy saving
- Long lifetime of 40,000 hours
- 36° beam angle
- CCT: 3000K 5000K
- No UV/IR light
- Environment friendly, without Mercury or any other hazardous substances

Application notes

- IP20 for indoor use only
- Professional electrician for installation only
- Switched off before installation
- Do not touch when in use
- Keep away from hot steam and corrosive gas

Application Areas

It is suitable for supermarket, specialty store, show window, exhibition hall, focus lighting, decorative and background lighting, where attention is focused on subjects to emphasize special visual points.

Certificate

CE RoHS

Product Information

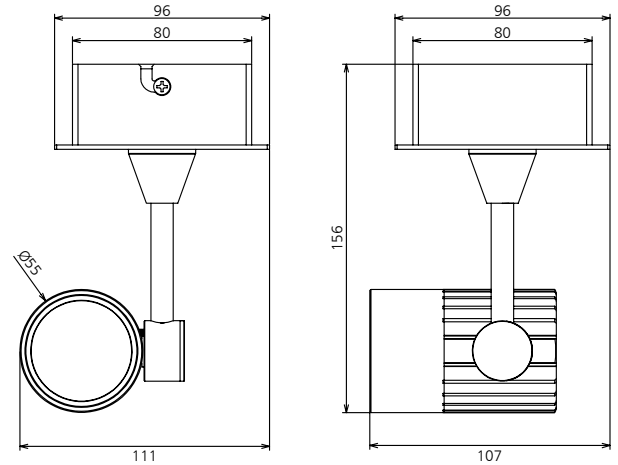

Technical Specifications

Model	Voltage	Power	Power Factor	Lumen (±5%)	Beam angle	CCT	Lifespan	CRI	Dimmable	Dimension
TL04-10W-B	AC230V	10W	≥0.9	870	36°	3000K	40000h	≥80	Yes	111*107*156mm
TL04-10W-B	AC230V	10W	≥0.9	920	36°	5000K	40000h	≥80	Yes	111*107*156mm

Driver data Sheet

Driver data	DIM
Input rated Voltage	AC230V
Frequency	50HZ
Input Voltage	AC200-240V
Efficiency	≥78%
Total load Wattage	10W±1W
Power Factor	≥0.9
Rated input current	≤0.06A
Full load output Voltage	28-38V
Rated output current	240mA
Output current range	240mA±5%
Power tolerance	±5%
Current output tolerance	±5%
Dimming range	8%-100%
Dimmer	Triac dimmers
Withstand voltage	AC1500V
Short circuit protection	PASS
Over voltage protection	PASS
Over temperature protection	PASS

Fixture Compatibility

Rated Wattage	Electrical Classification	Ingress Protection	Operating Temp	Operating Humidity	Storage Temp
10W	I	IP20	-20°C~45°C	0~90%	-20°C~65°C

Spectral Distribution

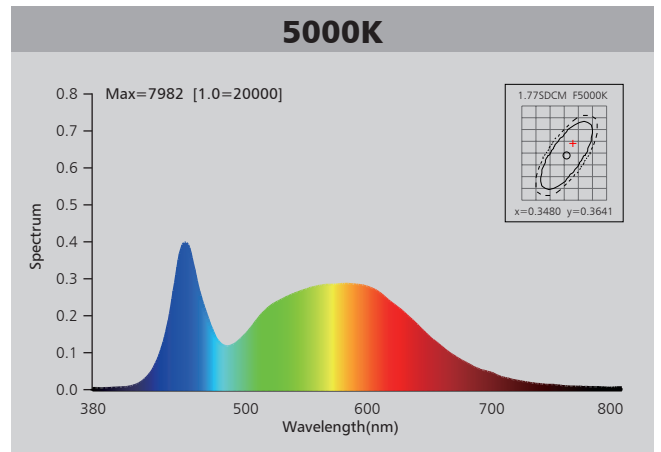
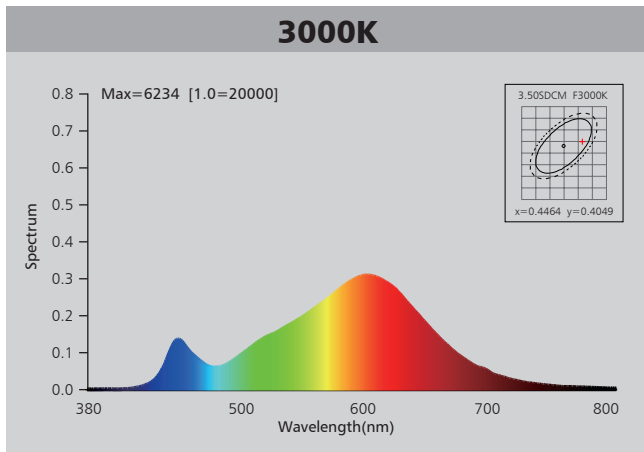

Photometric Diagram

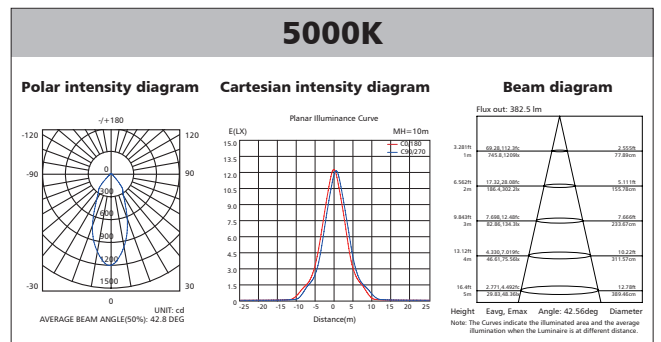
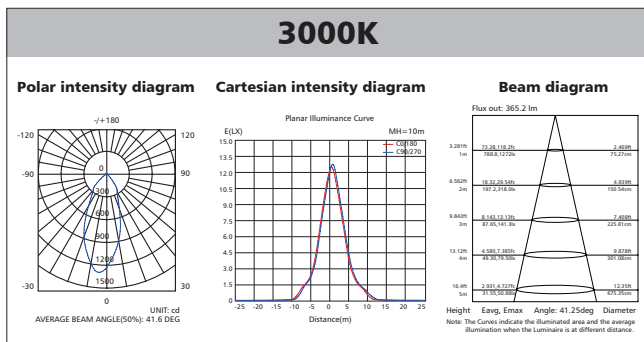

Polar Diagram Comparison

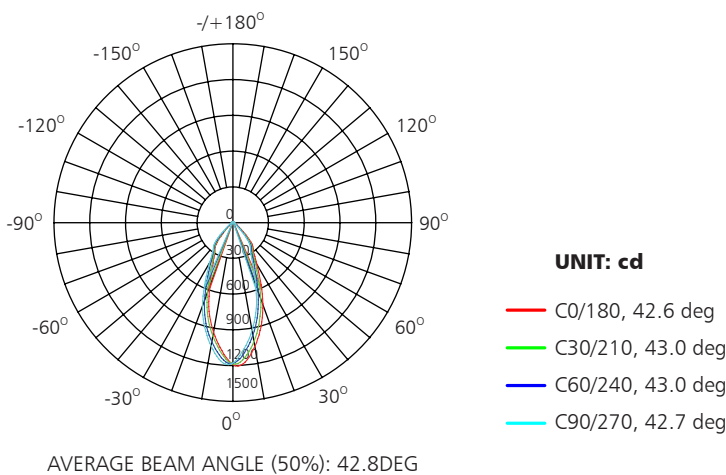

Driver lifetime & LED light decay rate

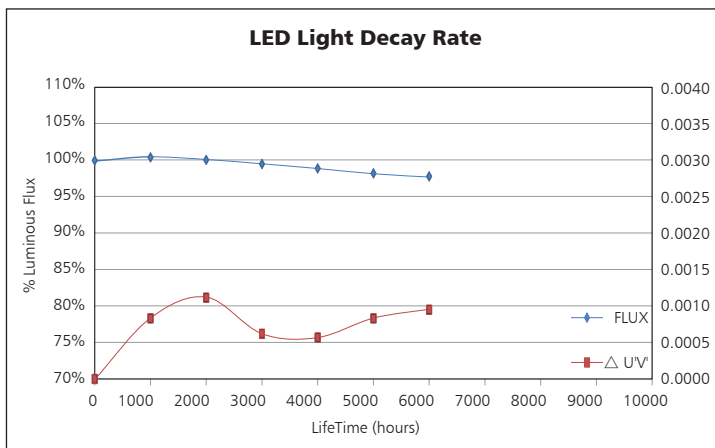
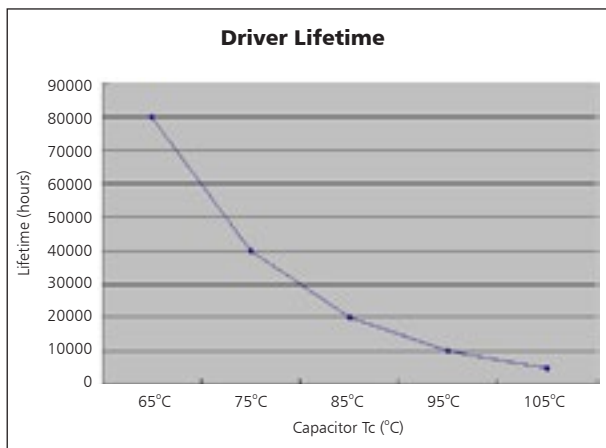

Temperature

- The testing is operated at 25°C
- The lifetime of capacitor, minimum of 5,000 hours if operated at 105°C, will be doubled whenever the temperature drops 10°C
- The highest withstand temperature of IC, MOS could be 120°C
- The highest withstand temperature of LED junction temperature is 150°C

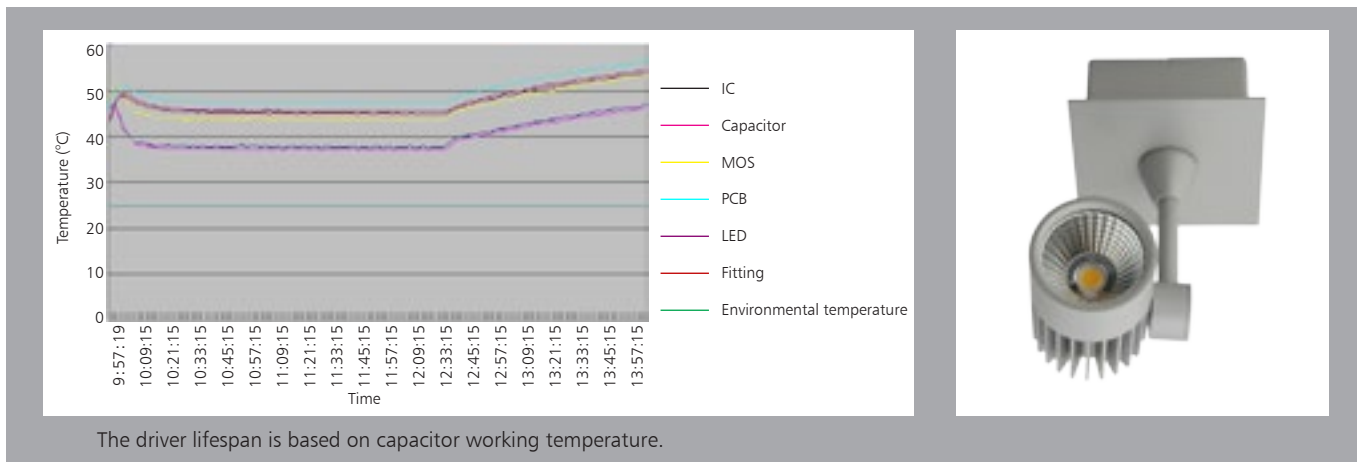

Ceiling mounted installation:

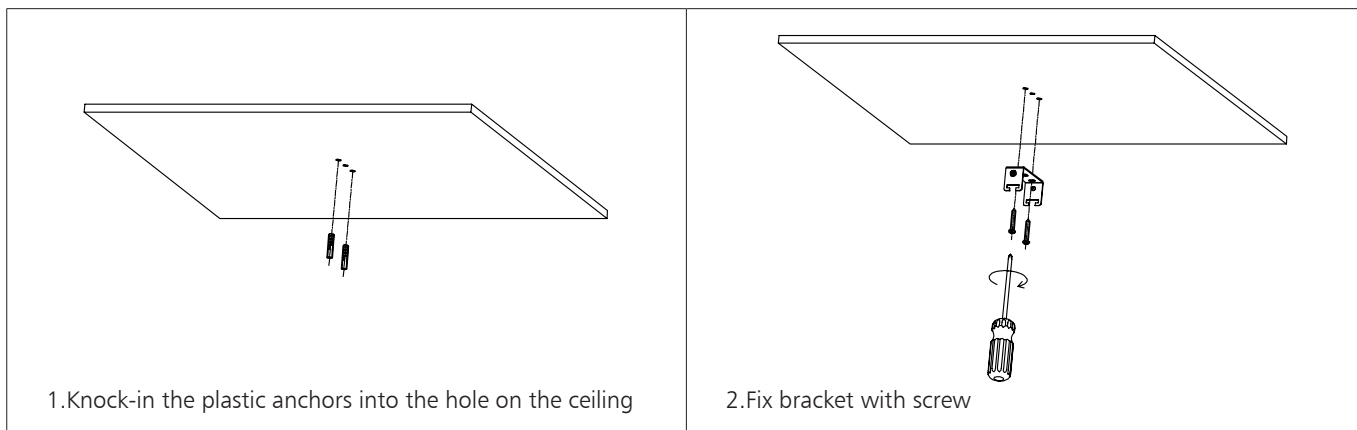

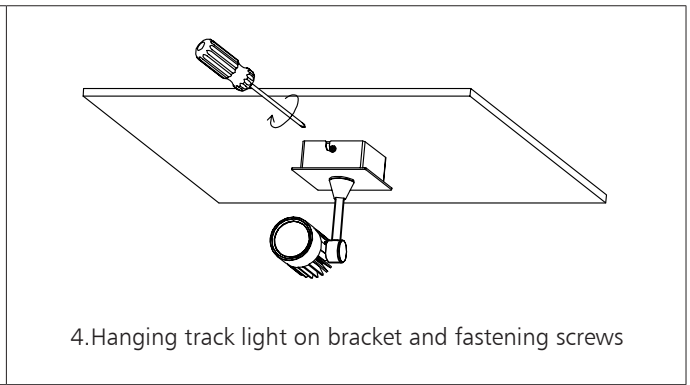
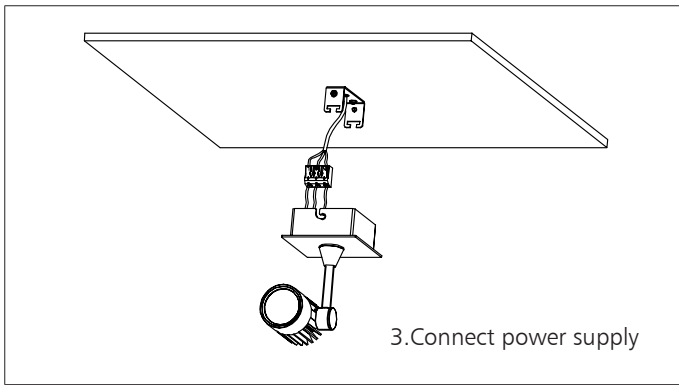

Embedded installation:

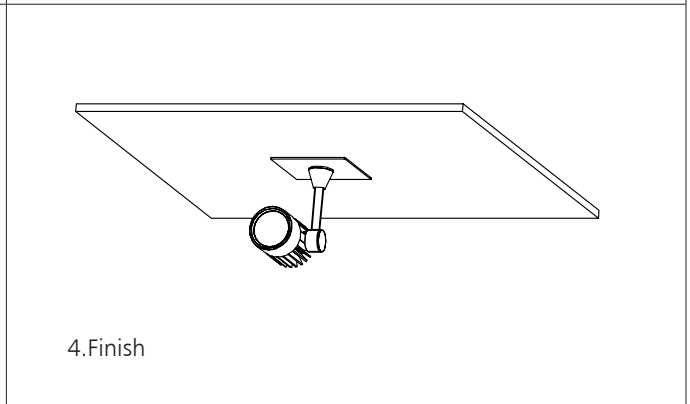
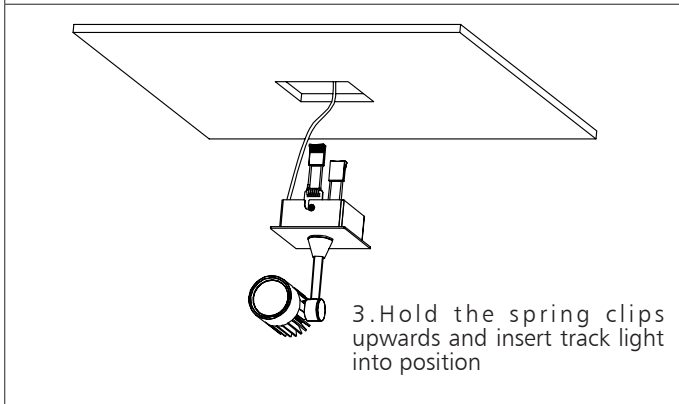
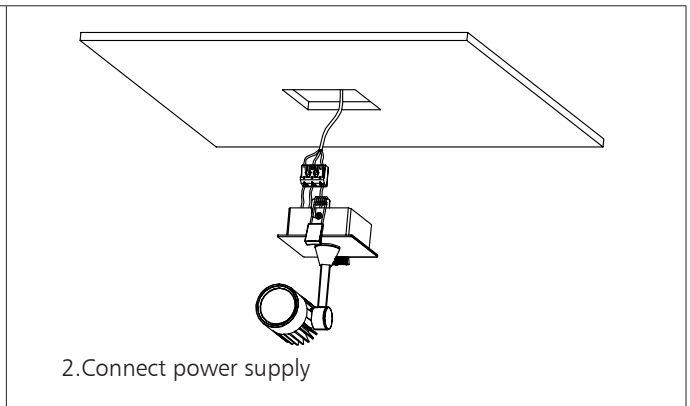
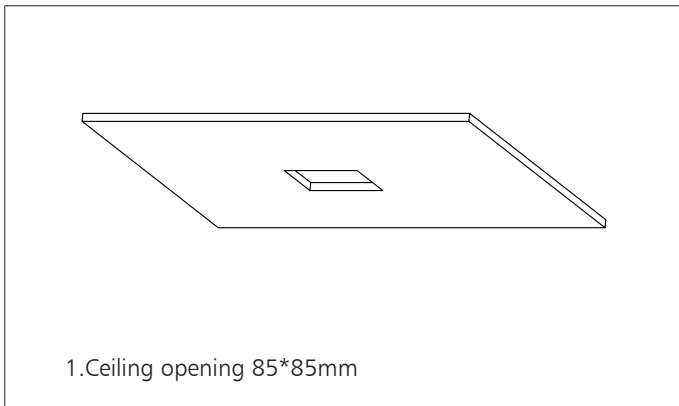

Packaging Information

	SIZE(CM)	N.W/pc (KGS)	G.W.(KGS)	Q'TY(PCS)
Carton	77.5*40.5*32.5	0.5	13.6	20

	CTNS	Q'TY(PCS)	VOLUME(CBM)
20" standard container	250	5000	28
40" standard container	500	10000	56

