



Technical Application
Guide for
LED Panel Light
PL6060-30W-A
PL6060-30W-A-D

Introduction



Featuring louver reflectors design technology, PL-A panel light offers the ideal combination of stylish design and optimum performance for both task and general lighting. Ensures optimum light distribution and full glare control in compliance with the latest office-lighting (UGR<13).

Features:

1. LED panel light back lit with louver reflectors design.
2. Lumen output: 3500Lm@4000K CRI 80.
3. luminous efficacy: 115 lm/w.
4. Ideal replacement for traditional 3x24W HO T5 and 3x18W T8 fluorescent louver luminaires, and side lit LED panel light .
5. Installation: Suspended / Recessed.
6. UGR<13.

Application notes

- IP40 for indoor use only
- Professional electrician for installation only
- Switch off before installation
- Do not touch when in use
- Keep away from hot steam and corrosive gas

Application Areas

Office & school lighting: office, meeting room, class room etc. Commercial lighting: shopping mall, super market, retailer shops etc. Other situations: hospital, laboratory, dust-free workshop etc.

Certificates

CE RoHS SAA



Product Information

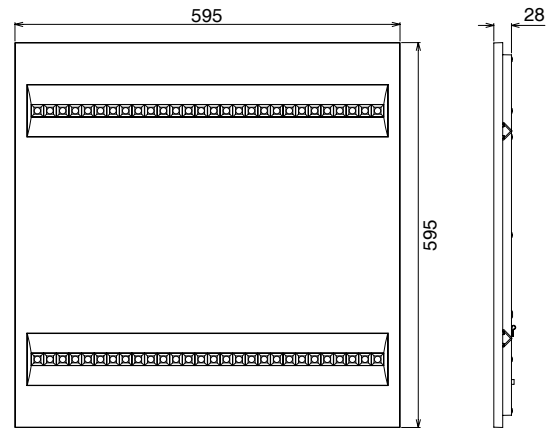

Technical Specifications

Model	Voltage	Power	Power Factor	Lumen (±5%)	CCT	Beam angle	Lifespan	CRI	Dimmable	Dimension
PL6060-30W-A	AC230V	30W	≥0.9	3150	3000K	90°	50000h	≥80	No	595*595*28mm
				3390	4000K					
				3450	5000K					
				3420	5700K					
PL6060-30W-A-D	AC230V	30W	≥0.9	3055	3000K	90°	50000h	≥80	Yes	595*595*28mm
				3290	4000K					
				3350	5000K					
				3320	5700K					

Driver data Sheet

Driver data	DIM	Non-dim
Input rated Voltage	AC230V	AC230V
Frequency	50Hz	50Hz
Input Voltage	AC200-240V	A220-240V
Efficiency	≥84%	≥86%
Total load Wattage	30W±5%	30W±5%
Power Factor	≥0.9	≥0.9
Rated input current	≤0.17A	≤0.17A
Full load output Voltage	DC23-40V	DC28-40V
Rated output current	700mA	720mA
Output current range	700mA±5%	720mA±5%
Power tolerance	±5%	±5%
Current output tolerance	±5%	±5%
Dimming range	8%-100%	—
Dimmer	Triac dimmers	—
Short circuit protection	PASS	PASS
Over voltage protection	PASS	PASS
Over temperature protection	PASS	PASS
Withstand voltage	AC3750V	AC3750V

Fixture Compatibility

Rated Wattage	Electrical Classification	Ingress Protection	Operating Temp	Operating Humidity	Storage Temp
30W	II	IP40	-20°C~45°C	0~90%	-20°C~65°C

Spectral Distribution

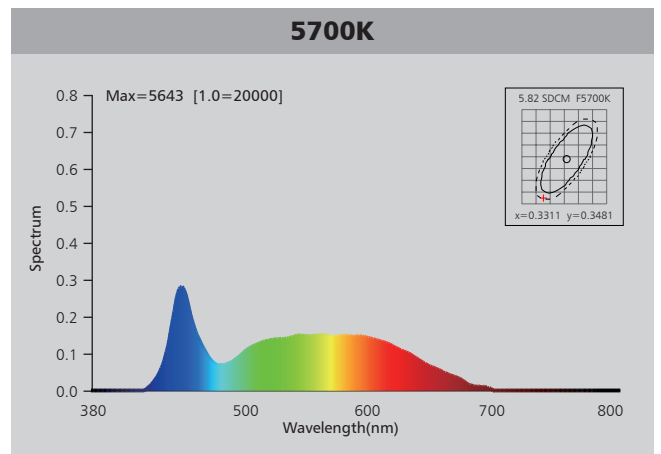
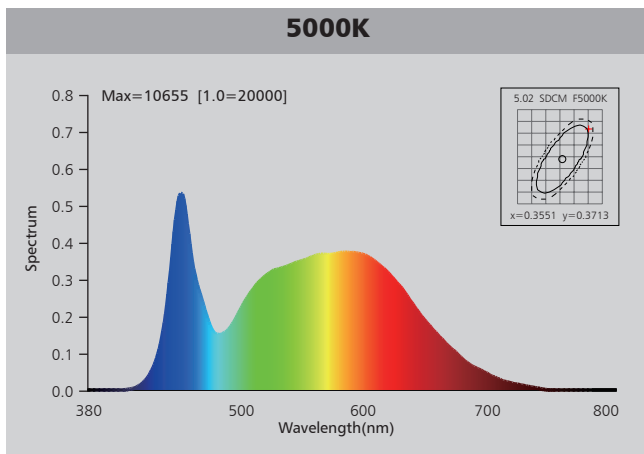
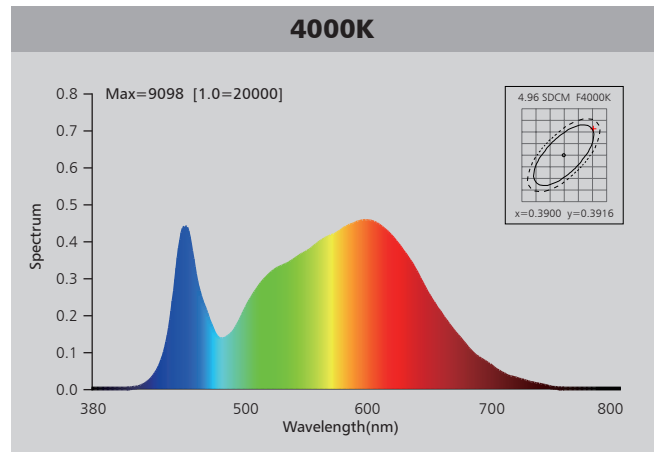
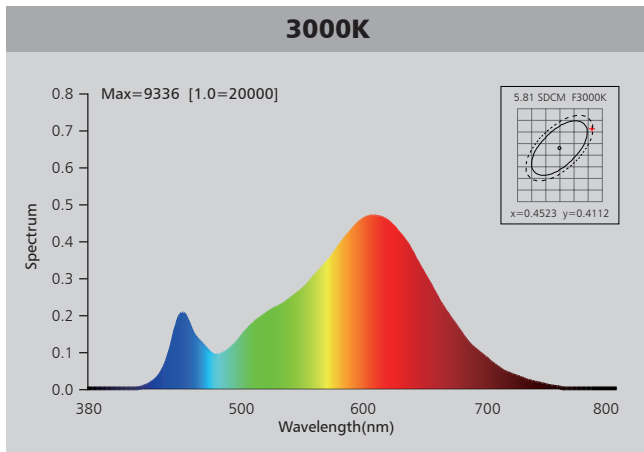

Photometric Diagram

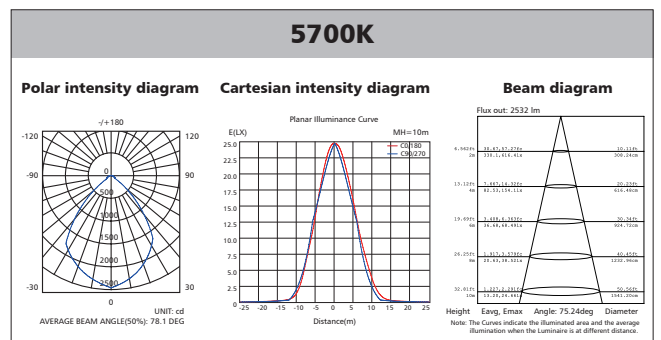
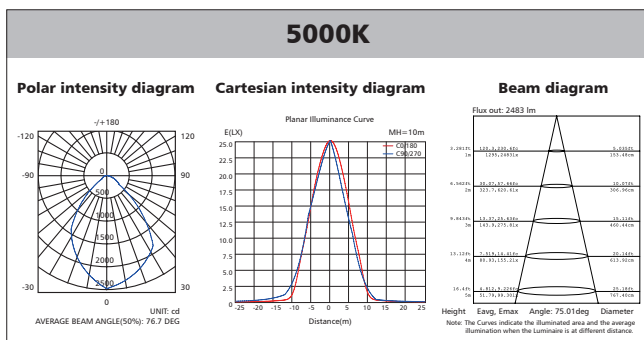
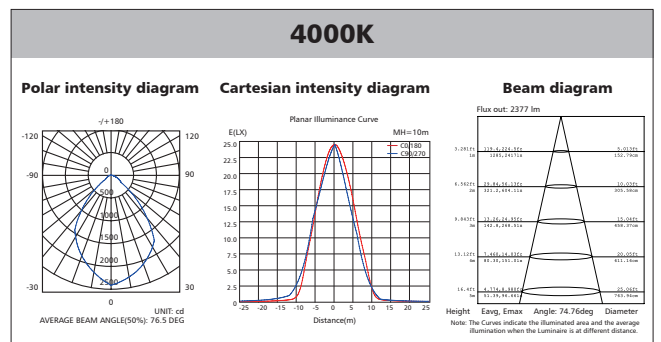
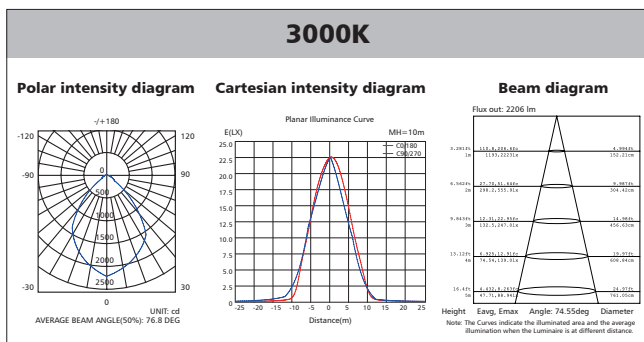

Polar Diagram Comparison

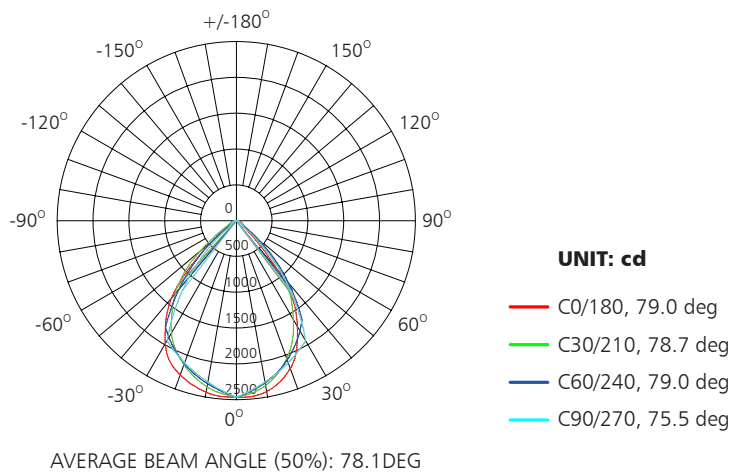

Driver lifetime & LED light decay rate

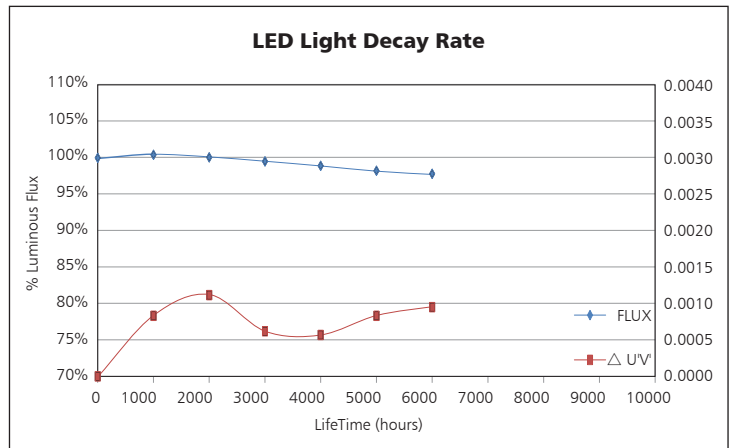
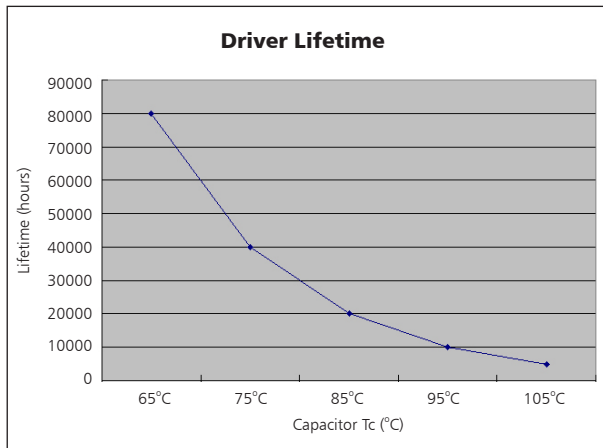

Temperature

- The testing is operated at 25°C
- The lifetime of capacitor, minimum of 5,000 hours if operated at 105°C, will be doubled whenever the temperature drops 10°C
- The highest withstand temperature of IC, MOS could be 120°C
- The highest withstand temperature of LED junction temperature is 150°C

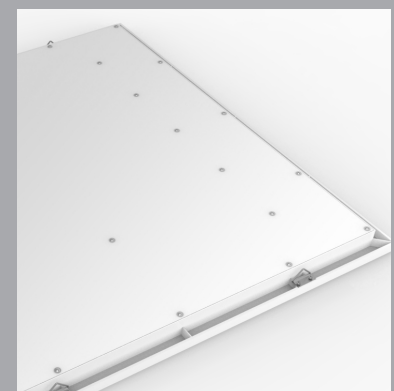
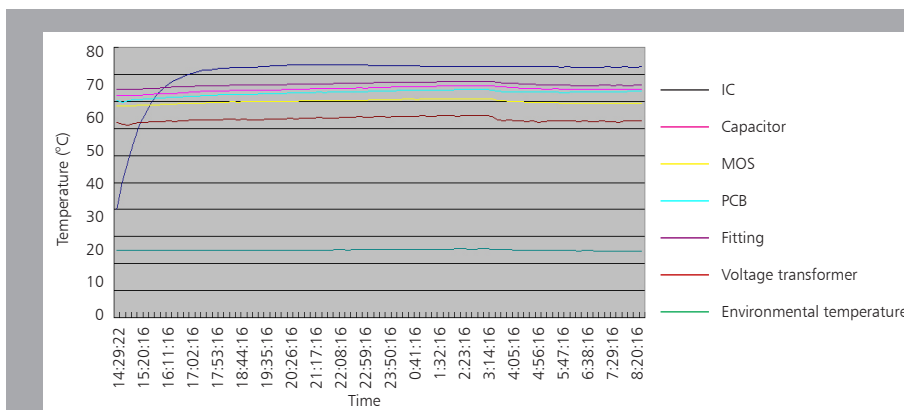

The driver lifespan is based on capacitor working temperature.

Installation

1. Recessed into ceiling

	<p>1. Remove ceiling plaster slab.</p>		<p>2. Connect the main AC wire L, N to the terminal of driver respectively. Connect the DC plug between driver and panel light.</p>
	<p>3. Fix the panel light to the plaster ceiling firmly.</p>		<p>4. Installation complete, turn on the power.</p>

2. Suspending

	<p>1. Knock the plastic anchor into ceiling.</p>		<p>2. Fix part A with tapping screw to ceiling, Wire rope goes through part B, and then screw B into A.</p>
	<p>3. Hanging the panel light to the suspending wires, connect the DC plug between driver and panel light.</p>		<p>4. Connect the main AC wire L, N to the terminal of driver respectively.</p>

Packaging Information

	SIZE(CM)	N.W/pc (KGS)	G.W.(KGS)	Q'TY(PCS)
Carton	66.5*38*72	3	18	5

	CTNS	Q'TY(PCS)	VOLUME(CBM)
20" standard container	152	760	28
40" standard container	306	1530	56

