

luzon
lighting™

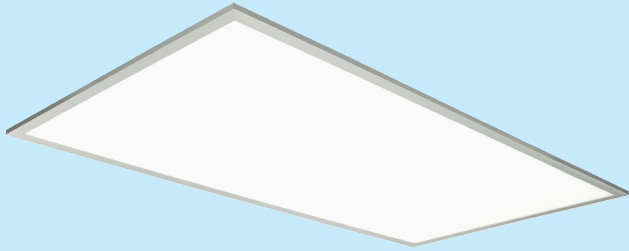

Technical Application Guide for LED
Panel Light
PL60120-72W-L

Introduction



Double-sided panel light is designed for special use with decorative effect. 70% light downward and 30% light upward, it is only suitable for suspended installations. Adopts high lumen SMD, CRI >80, top branded driver comes with dimmable function. High quality LGP creates extremely uniform light. It is an ideal choice for commercial and residential applications.

- Up to 80% energy saving compared to standard CFL
- Long lifetime of 40,000 hours
- 120° wide beam angle
- CCT: 3000K 4000K
5000K 5700K
- No UV/IR light
- Environment friendly, without Mercury or any other hazardous substances

Application notes

- IP40 for indoor use only
- Professional electrician for installation only
- Switch off before installation
- Do not touch when in use
- Keep away from hot steam and corrosive gas

Application Areas

Office & school lighting: office room, meeting room, class room etc.

Commercial lighting: shopping mall, super market, retailer shops etc.

Other situations: hospital, laboratory, dust-free workshop etc.

Certificates

CE **RoHS** **SAA**



Product Information

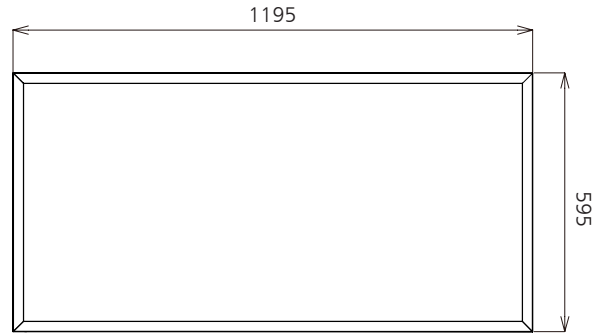
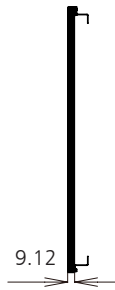
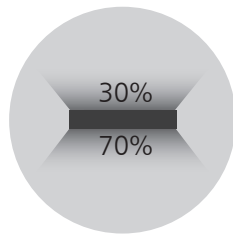

Technical Specifications

Model	Voltage	Power	Power Factor	Lumen (±5%)	Beam angle	CCT	Lifespan	CRI	Dimmable	Dimension
PL60120-72W-L	AC100-240V	72W	≥0.9	4520	120°	3000K	40000h	≥80	No	1195*595*9.12mm
PL60120-72W-L	AC100-240V	72W	≥0.9	4650	120°	4000K	40000h	≥80	No	1195*595*9.12mm
PL60120-72W-L	AC100-240V	72W	≥0.9	4720	120°	5000K	40000h	≥80	No	1195*595*9.12mm
PL60120-72W-L	AC100-240V	72W	≥0.9	4770	120°	5700K	40000h	≥80	No	1195*595*9.12mm

Driver data Sheet

Driver data	Non-dim
Input rated Voltage	AC100-240V
Frequency	50/60Hz
Input Voltage	AC85-265V
Efficiency	≥85%
Total load Wattage	72W±5%
Power Factor	≥0.9
Rated input current	≤0.8A
Full load output Voltage	DC35-38V
Rated output current	1750mA
Output current range	1750mA±5%
Power tolerance	±5%
Current output tolerance	±5%
Dimming range	—
Dimmer	—
Short circuit protection	PASS
Over voltage protection	PASS
Over temperature protection	PASS
Withstand voltage	AC3750V

Fixture Compatibility

Rated Wattage	Electrical Classification	Ingress Protection (IP)	Operating Temp	Operating Humidity	Storage Temp
72W	II	IP40	-20°C~45°C	0~90%	-20°C~65°C

Spectral Distribution

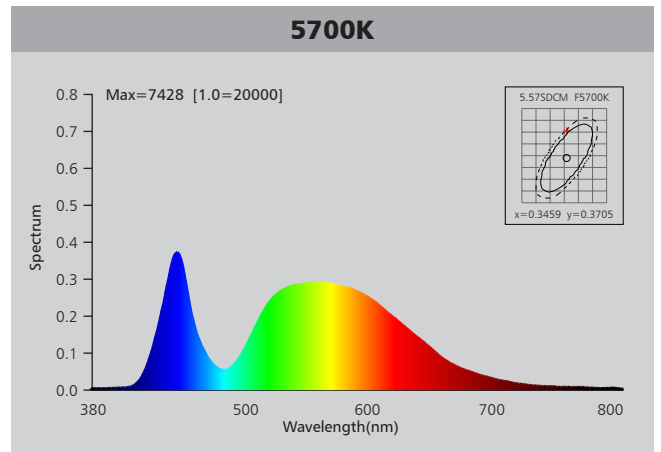
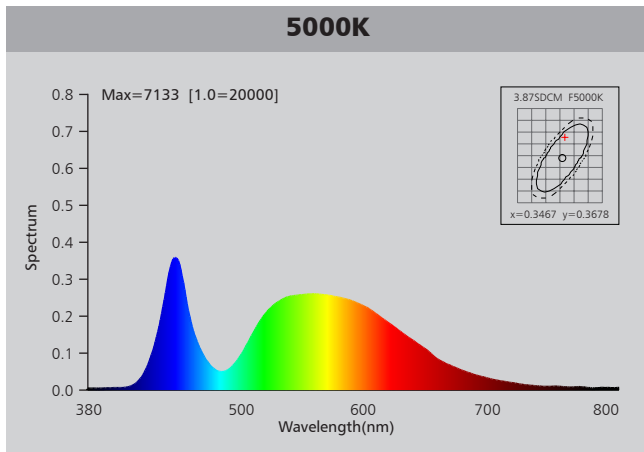
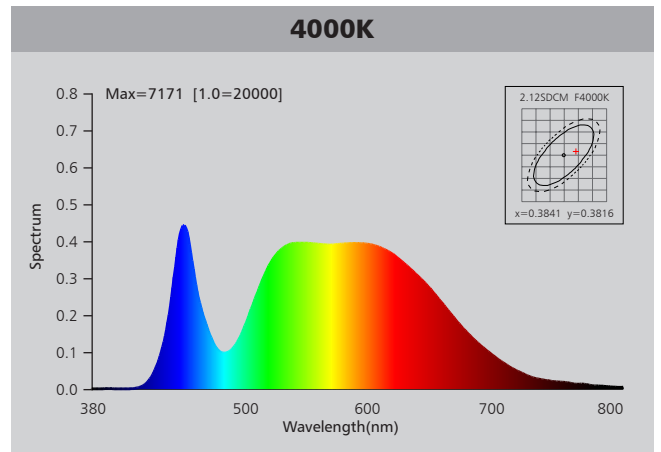
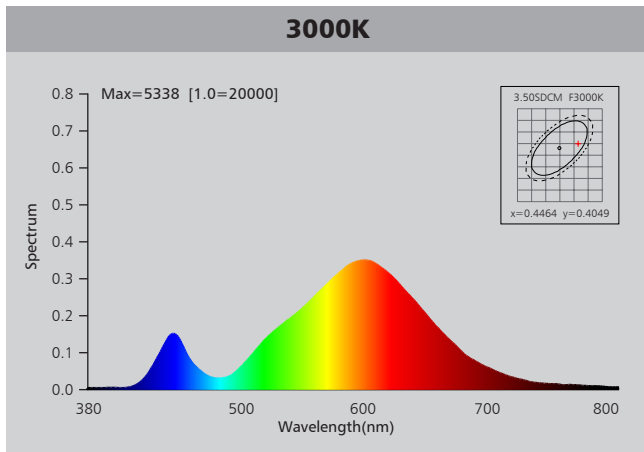

Photometric Diagram

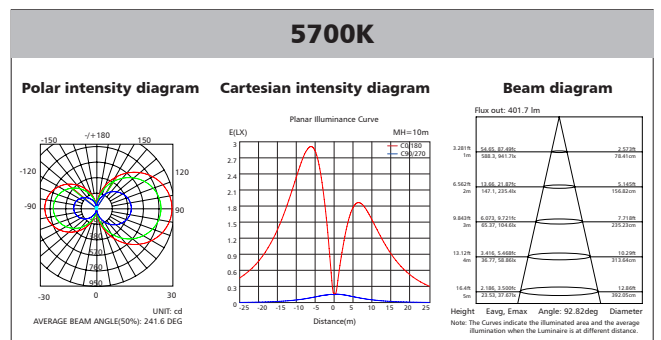
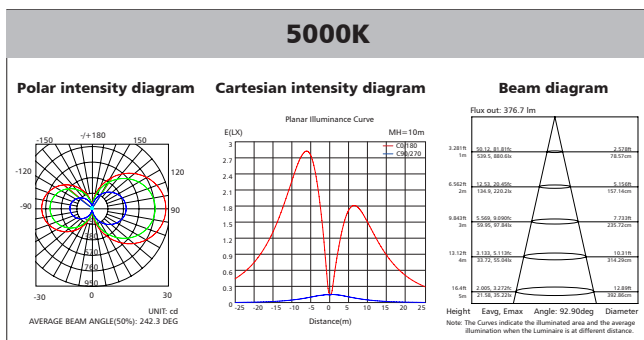
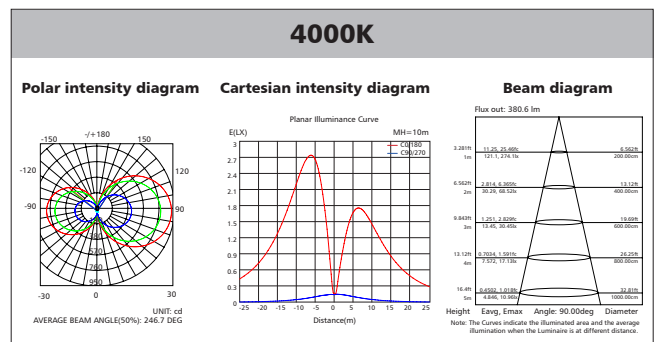
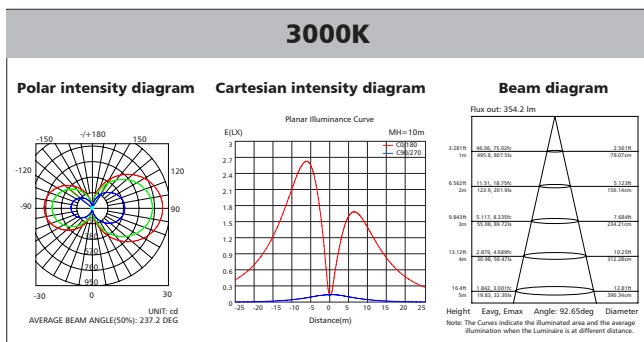

Polar Diagram Comparison

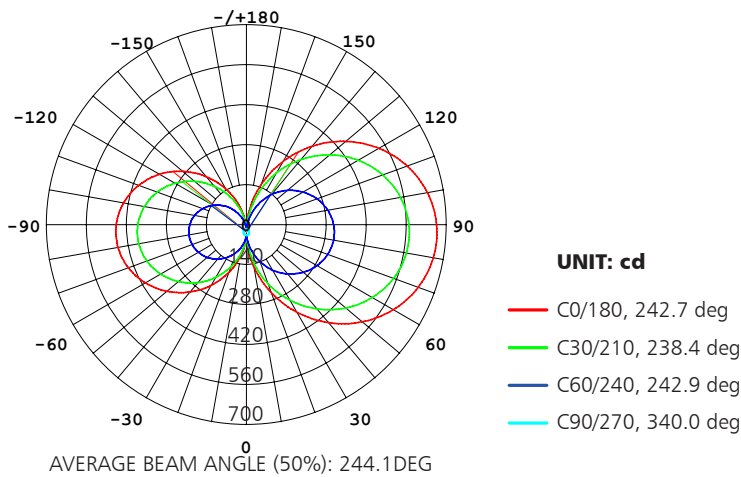

Driver lifetime & LED light decay rate

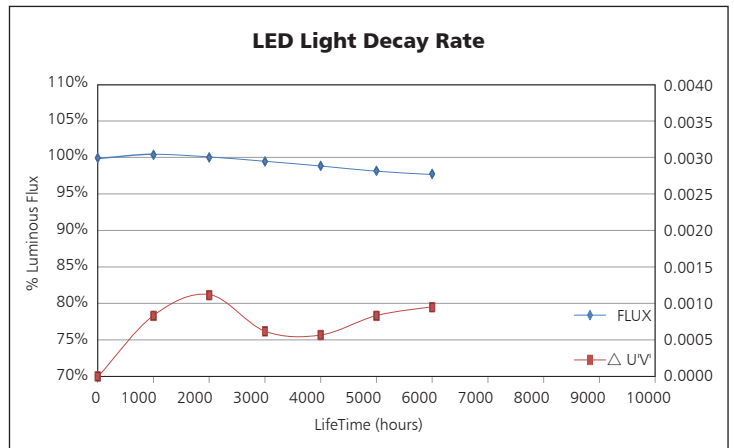
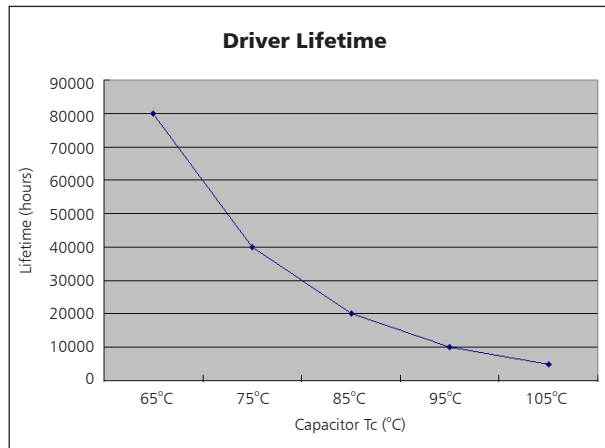

Temperature

- The testing is operated at 25°C
- The lifetime of capacitor, minimum of 5,000 hours if operated at 105°C, will be doubled whenever the temperature drops 10°C
- The highest withstand temperature of IC, MOS could be 120°C
- The highest withstand temperature of LED junction temperature is 150°C

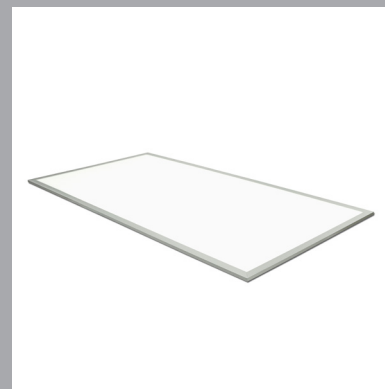
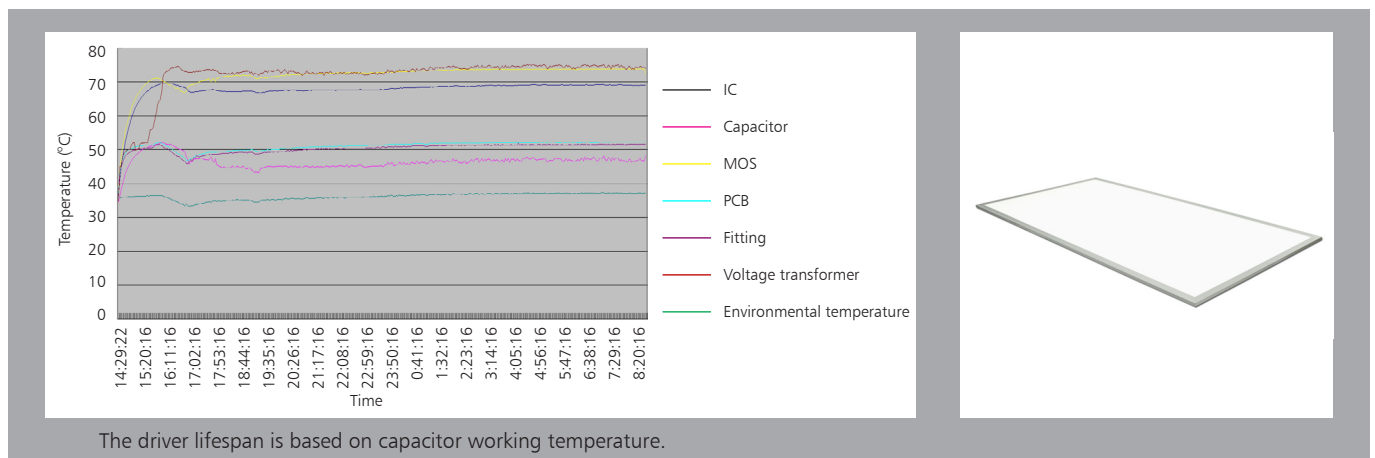

Installation

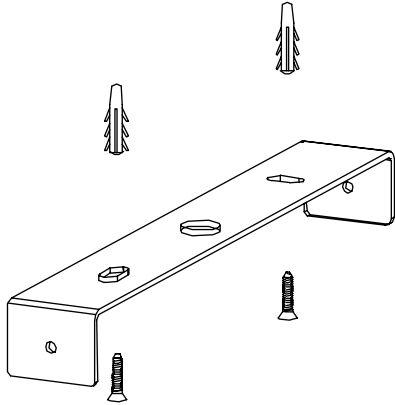
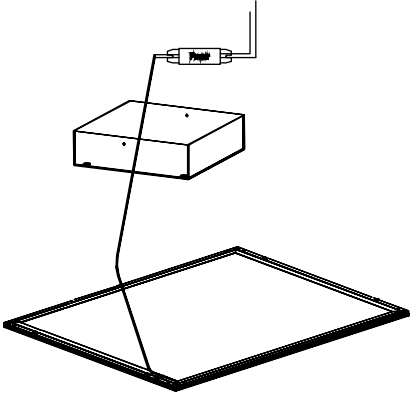
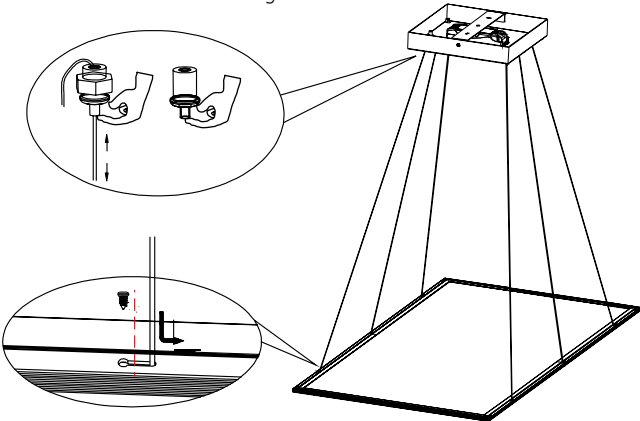
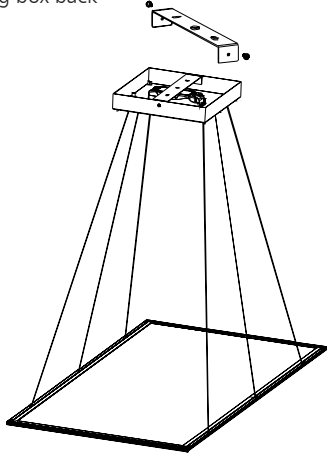
<p>1. Fastening the bracket on the ceiling with plastic anchor and screw.</p> 	<p>2. Put the DC line through the mounting box and connect the power supply.</p> 
<p>3. Connect one end of steel wire with panel, another end with mounting box.</p> 	<p>4. Hang the mounting box back to the bracket.</p> 

Packaging Information

	SIZE(CM)	N.W/pc (KGS)	G.W.(KGS)	Q'TY(PCS)	CTNS	Q'TY(PCS)	VOLUME(CBM)	
Carton	157.5*14.5*69	7.8	23.5	2	20" standard container	175	350	28
					40" standard container	350	700	56

