

Entry / ENT

Standard / STD

Professional / PRO

ODM & OEM

2019

STD
Specifications

LED Track
TL49 Series



luzon
lighting™



Introduction

This is a LED linear track light with louver reflector design. it's widely used as additional lighting compared with traditional spot track light. Adopt 2835SMD chip, louver reflector make it anti-glare, 6063 aluminum provides good heat dissipation. Adjustable lighting orientation with 350° in horizontal direction and 220° in vertical direction.

Features

- Linear track light for additional lighting
- UGR<19 with louver reflector design
- Beam angle 60°
- Three size option:320mm/420mm/530mm
- Finish color: Blank/White
- Flicker free with internal driver
- 1-circuit and 3-circuits are all available

Application Areas

It is suitable for supermarket, specialty store, show window, exhibition hall; focus lighting, decorative and background lighting, where attention is focused on subjects to emphasize special visual points.

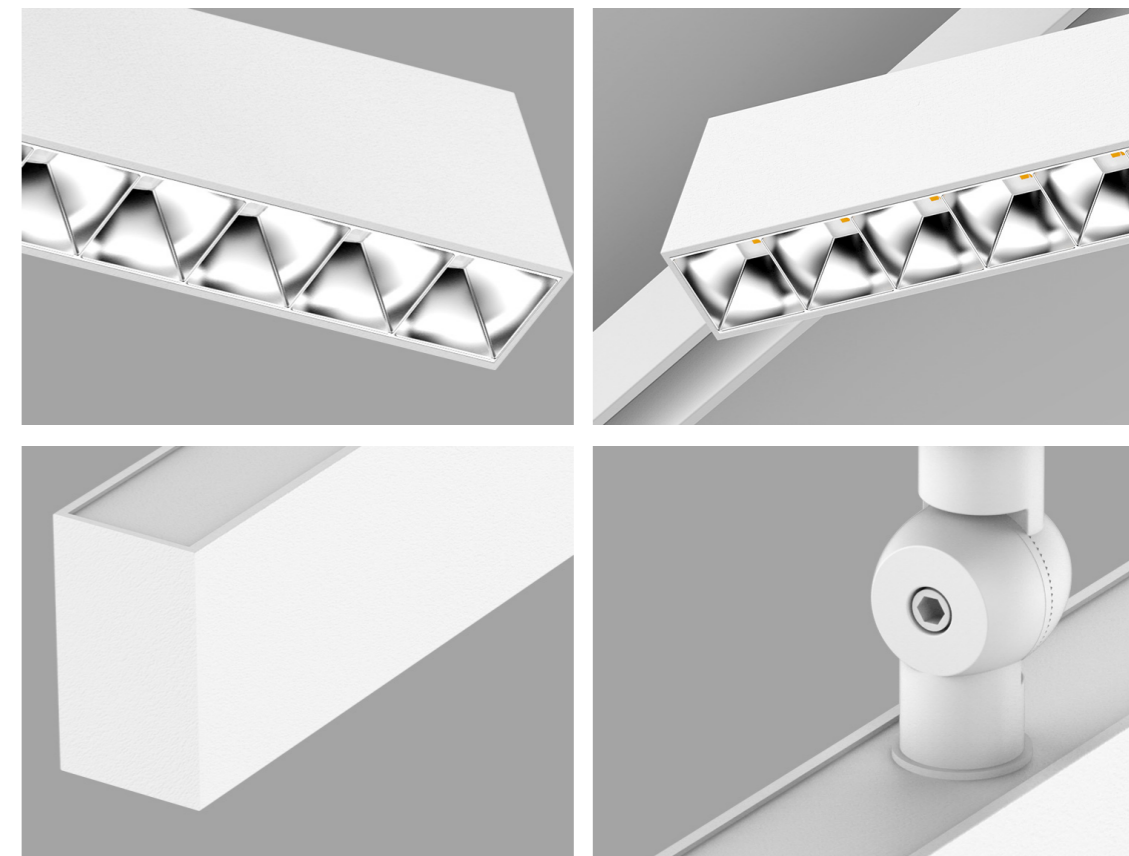

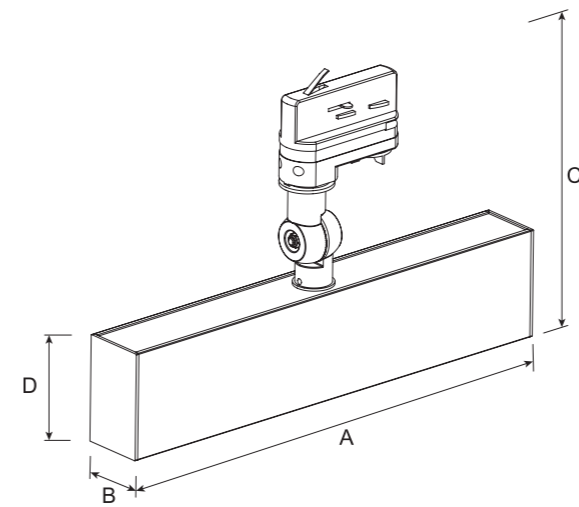

Technical Data Sheet

Model No.	TL49-15W	TL49-30W	TL49-37W	TL49-45W		
Dimension(mm)	319.5*42*195.5	424.5*42*195.5	529.5*42*95.5	529.5*42*195.5		
Cutout (mm)	-	-	-	-		
Watt(W)	15W	30W	37W	45W		
Rated Input Voltage(V)	AC230V					
Input Voltage(V)	AC220-240V					
LED Module Input	-					
Light Source	SMD					
SDCM	<6					
CCT(K)	3000K / 4000K / 5000K / 5700K					
CCT Selection DIP Switch	-					
Luminous Flux (lm) ±5%	Non-DIM	1-CCT	1300~1450	2550~2850	3250~3500	3650~4000
	DIM		-	-	-	-
	Non-DIM	3-CCT	-	-	-	-
	DIM		-	-	-	-
CRI	≥80					
Beam Angle (°)	60°					
UGR	<19					
LED Driver	Built-in					
Dimming Option	-					
Sensor	-					
Emergency Kits	-					
Electrical Class	Class I					
Ingress Protection (IP Rating)	IP20					
Impact Resistance (IK Rating)	IK06					
Product Finishing(Base)	White RAL 9016 / Black RAL 9005					
Materials of Optics	PC+ABS					
Materials of Housing	Aluminum					
Lifetime (hr)	50,000h					
Glow wire test (°C)	750°C					
Operating Temp. (°C)	-20°C ~45°C					
Storage Temp. (°C)	-20°C ~65°C					
Installation	Track					

Measurement

Model	Dimension(mm)				Size(mm)	Product Weight (Kg)		Package weight (Kg)		Carton Size(cm)	Qty/CTN	20GP (pcs)	40HQ (pcs)
	A	B	C	D		N.W/PC	G.W/PC	N.W/CTN	G.W/CTN				
15W	319.5	42	19.5	70	319.5*42*195.5	0.735	0.8	8.9	12.5	50*37*50	12	3312	8400
30W	424.5	42	19.5	70	424.5*42*195.5	0.915	1	11	15	50*47.5*50	12	2304	5760
37W	529.5	42	19.5	70	529.5*42*195.5	1.15	1.25	13.8	17	58*50*50	12	2064	5340
45W	529.5	42	19.5	70	529.5*42*195.5	1.15	1.25	13.8	17	58*50*50	12	2064	5340

Driver Datasheet (Non-Dimmable)

Total load wattage		15W	30W	37W	45W
Output	Output Voltage range	DC33-42V	DC33-42V	DC33-42V	DC33-42V
	Rated output current	350mA	700mA	950mA	1100mA
	Line Regulation	±5%			
	Setup, Rise Time	0.5S			
	Flickering Index	<5%			
Input	Input Voltage	AC230V			
	Rated Input Voltage(V)	AC220-240V			
	Frequency	50/60Hz			
	Input Current	≤0.15A	≤0.3A	≤0.3A	≤0.4A
	Rated Input Current	≤0.072A	≤0.15A	≤0.18A	≤0.22A
	Power Factor	0.9			
	THD	-	<20% @ 230V		
	Efficiency	≥86%	≥88%	≥88%	≥88%
	No load wattage	0.5W			
	Protection	Short circuit protection	Pass		
Over voltage protection		Pass			
Over temperature protection		Pass			
Safety & EMC	Withstand voltage	I/P-O/P:3.75KVac, <5mA 60S			
	Isolation Resistance	I/P-O/P: 500VDC, ≥100M Ω			
	Inrush Current	IEC61000-4-5(L-N:1KV, L/N-PG:2KV)			
	EMC Emission	EN55015, EN61000-3-2			
EMC Immunity	EN61000-4-2,3,4,5,6,8,11; EN61547				

Installation Procedure

WARNING ⚡

- 1. Switch off before installation / maintenance.
- 2. Switch on only after complete installation and examination of the circuit.
- 3. Professional electrician for installation and maintenance only.



Turn Off power supply before starting any installation. Read instructions & check you have all the tools & accessories to complete the installation correctly.

How to install

Step 1

Prior to locating Adaptor into Track Section make sure it is set in the 'OFF' position & 'Locking Lever' is set in the position shown.

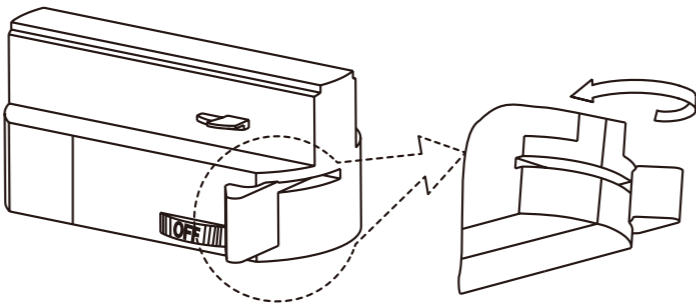

2-wires, 3-wires adaptor

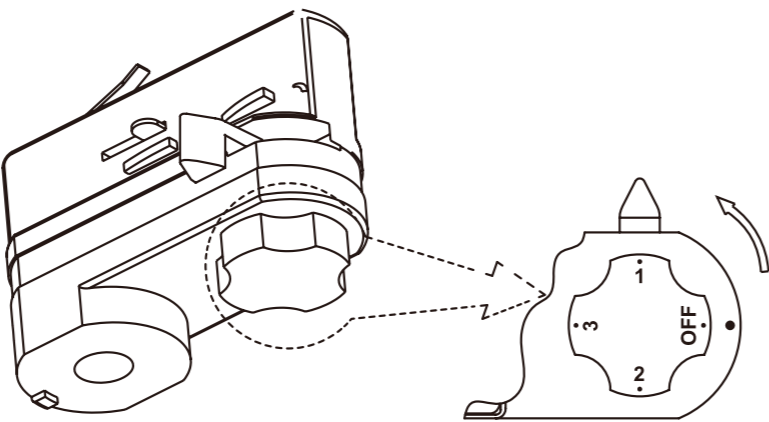

4-wires adaptor

Step 2

Locate Track Adaptor into Track Section (1) & lock into position by turning 'Locking Lever' 90°(2)

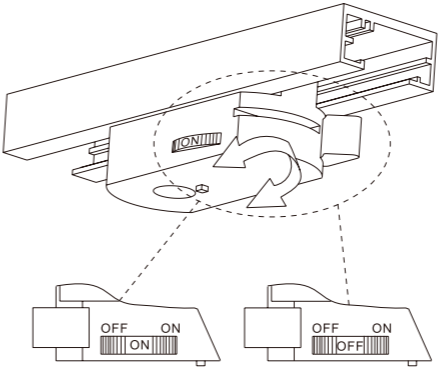

2-wires, 3-wires control luminaires in same circuit by ON/OFF switch.

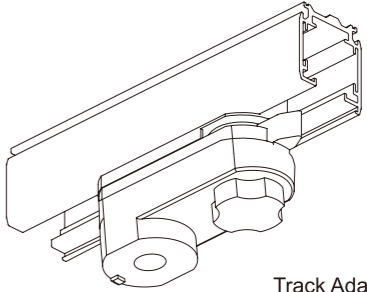
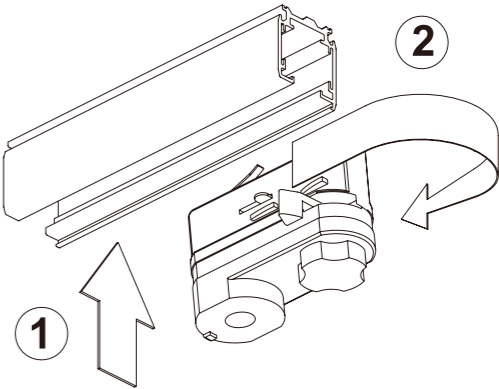

Track Section

Track Adaptor shown locked into Track Section

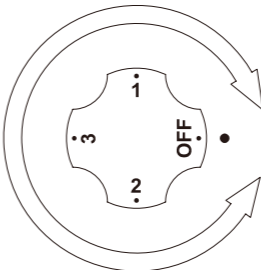

4-wires Turn clockwise or anti-clockwise.

2019
ECO
Specifications

2019
STD
Specifications

2019
PRO
Specifications

2019
ODM
Specifications