

# LED PANEL LIGHT

PL-AZ

**luzon**  
lighting™

# Introduction



◀ Featuring louver reflectors design technology makes low glare, PL-AZ panel offers the ideal combination of stylish design and optimum performance for both task and general lighting, the luminous module can be replaced, which ensure the easy maintenance.

## Features

1. With louver reflectors design (low glare  $UGR < 19$ ).
2. Lumen efficacy: 100-115lm/W.
3. Module materials adopts 94-V0 PC.
4. Ideal replacement for traditional 3\*24W HO T5 and 3\*18W T8 fluorescent louver luminaries and side lit LED panel light.
5. Installation: Recessed / Suspended.

## Application Areas

Office & school lighting: office room, meeting room, class room etc. Commercial lighting: shopping mall, super market, retailer shops etc. Other situations: hospital, laboratory, dust-free workshop etc.

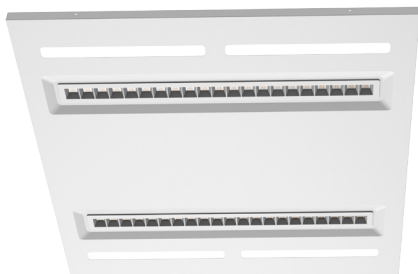
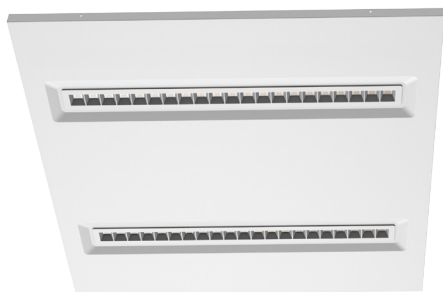

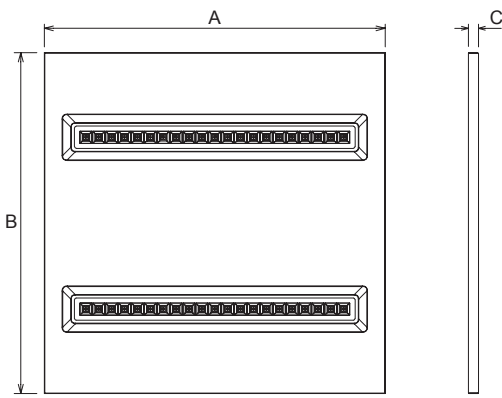

## Measurement

Model	Dimension(mm)			Size(mm)	Product Weight (Kg)		Package weight (Kg)		Carton Size(cm)	Qty/CTN	20GP (pcs)	40HQ (pcs)
	A	B	C		N.W/PC	G.W/PC	N.W/CTN	G.W/CTN				
6060	595	595	15	595*595*15	3.2	3.9	12.8	18	66*20*71	4	1056	2244
30120	1195	295	15	1195*295*15	3.6	4.3	14.4	19.5	130*20*36	4	1056	2772

## Technical Data Sheet

Model No.	PL6060-30W-AZ		PL6060-35W-AZ		PL30120-30W-AZ		PL30120-35W-AZ	
Watt(W)	30W		35W		30W		35W	
Dimension(mm)	595*295*15		595*595*15		1195*295*15		1195*295*15	
Rated Input Voltage(V)	AC230V							
Input Voltage(V)	AC220-240V							
LED	SMD							
SDCM	-							
CCT(K)	1-CCT: 3000K / 4000K / 5000K / 5700K    3-CCT: 3000K+4000K+5700K							
"Luminous Flux (lm) ±5%	1-CCT	Non-DIM	2950-3450	3300-3950	2950-3450	3300-3950		
		DIM	2800-3280	3135-3750	2800-3450	3135-3750		
	3-CCT	Non-DIM	2900-3200	3300-3600	2900-3200	3300-3600		
		DIM	2755-3050-	3150-3450	2755-3050	3150-3450		
CRI	≥80							
Beam Angle (°)	90°							
LED Driver	Built-out							
DIM	Triac							
Protection Class	Class II							
IP Rating	IP20							
Finishing color	White RAL 9016							
Material	PC / SPCC							
Lifetime (hr)	50,000h							
Glow wire test (°C)	650°C							
Operating Temp.(°C)	-20°C ~40°C							
Storage Temp.(°C)	-20°C ~65°C							
Installation	Pendant / Recessed							
Brand Driver option	Philips, Tridonic, Meanwell							

## Driver Datasheet ( Non-Dimmable)

Power	30W	35W
Rated Input Voltage(V)	AC230V	
Frequency	50/60Hz	
Input Voltage	AC220-240V	
Efficiency	85%	85%
Total load wattage	30W±5%	35W±5%
Power Factor	0.9	
Rated Input Current	0.16A	0.18A
Full load output voltage	DC28-40V	DC28-40V
Rated output current	720mA	850mA
Output current range	720mA±5%	850mA±5%
Power tolerance	±5%	
Current output tolerance	±5%	
Short circuit protection	PASS	
Over voltage protection	PASS	
Over temperature protection	PASS	
THD	<20% @ 230VAC	
Surge	L-N 1KV	
Withstand voltage	AC3750V	

## Driver Datasheet ( Dimmable)

Power	30W	35W
Rated Input Voltage(V)	AC230V	
Frequency	50Hz	
Input Voltage	AC200-240V	
Efficiency	85%	85%
Total load wattage	30W±5%	35W±5%
Power Factor	0.9	
Rated Input Current	0.17A	0.2A
Full load output voltage	DC23-40V	DC23-40V
Rated output current	700mA	800mA
Output current range	700mA±5%	800mA±5%
Power tolerance	±5%	
Current output tolerance	±5%	
Dimming Range	8%~100%	
Short circuit protection	PASS	
Over voltage protection	PASS	
Over temperature protection	PASS	
THD	<18% @ 230VAC	
Surge	L-N 1KV	
Withstand voltage	AC3750V	

# Installation Procedure

## WARNING ⚡

1. Switch off before installation.
2. Switch on only after complete installation and examination of the circuit.
3. Professional electrician for installation and maintenance only.

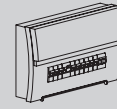

Turn Off  
Power Supply

Turn Off power supply before starting any installation. Read instructions & check you have all the tools & accessories to complete the installation correctly.

### Recessed into ceiling

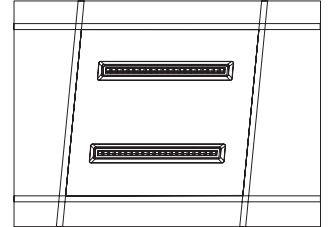
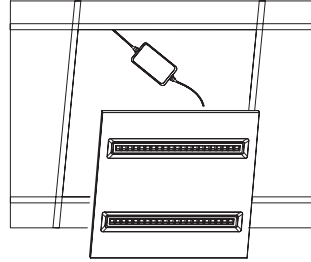
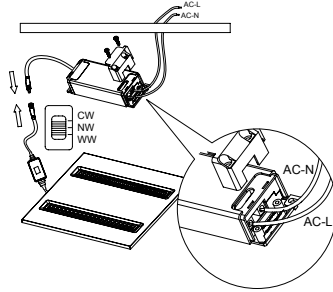
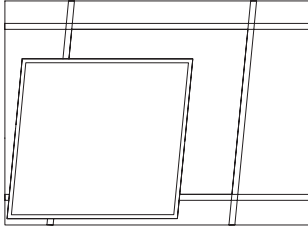

1. Remove ceiling plaster slab.
2. Connect the main AC wire L, N to the terminal of driver respectively. Connect the DC plug between driver and panel light. (Model dependent Choose teh CCT by slide sitch)
3. Fix the panel light to the plaster ceiling firmly.
4. Installation complete, turn on the power.

### Suspending

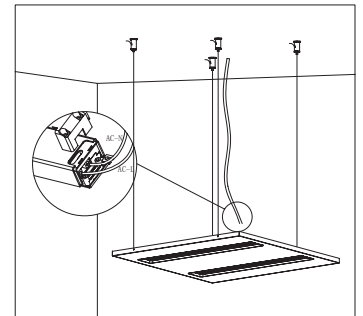
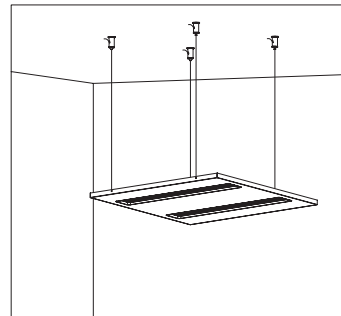
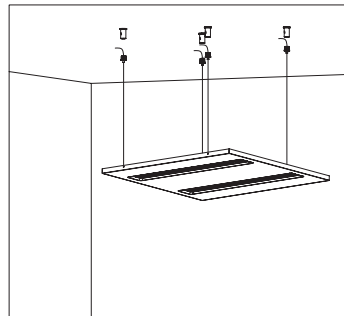
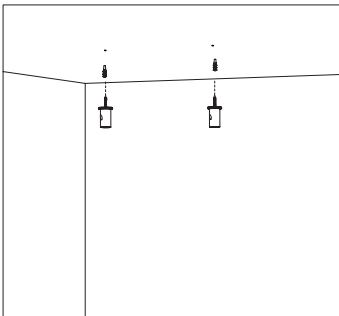

1. Knock the plastic anchor into ceiling, Fix part A with tapping screw to ceiling,
2. Hanging the panel light to the suspending wires, Wire rope goes through part B,
3. screw B into A. Connect the DC plug between driver and panel light.
4. Connect the main AC wire L, N to the terminal of driver respectively.