

LUZON-HL09

Instruction Manual

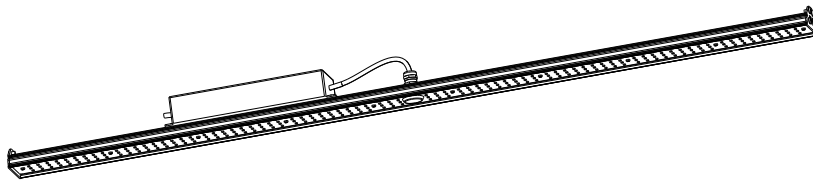

150W

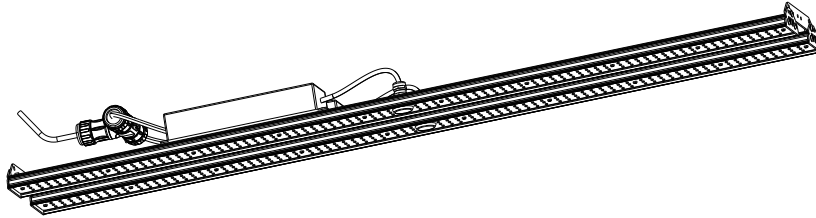

300W



Physical Dimensions(Unit: mm)

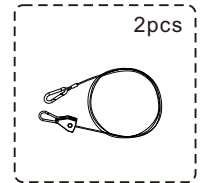
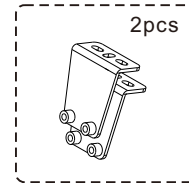
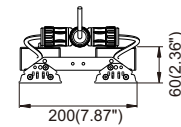
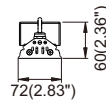
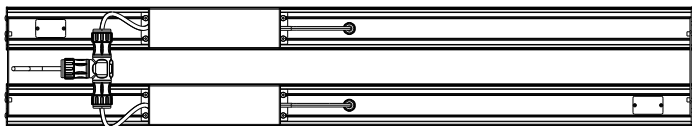
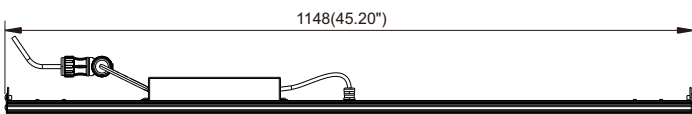
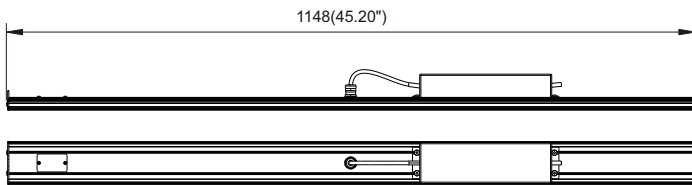

Product Specifications	150W	300W
Size (L x W x H)	1148X72X60mm (45.20"x2.83"x2.36")	1148X200X60mm (45.20"x7.87"x2.36")
Weight (Driver included)	2.1±0.3kg (4.63±0.66Lbs)	4.4±0.3kg (9.70±0.66Lbs)
Input Voltage	100-240VAC / 100-277VAC	
Working Temperature	0°C to +40°C(32°F to +104°F)	
Storing Temperature	-40°C to +70°C(-40°F to +158°F)	

A. Ceiling installation

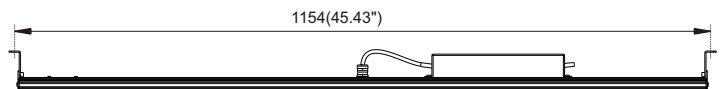
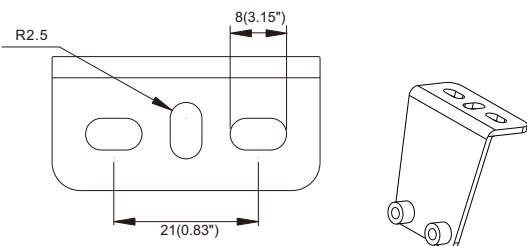

Product Specifications	150W	300W
Size (L x W x H)	1154x21(45.43"x0.83")	

②

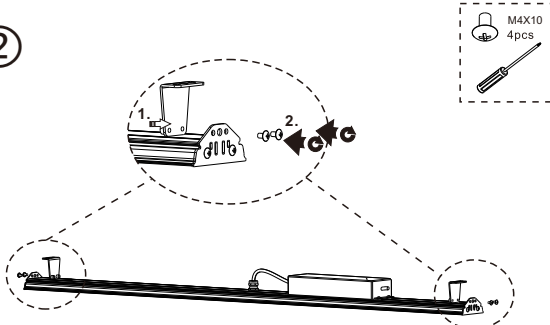

③

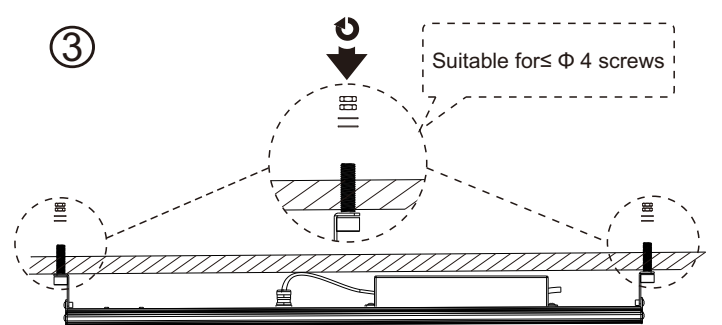

LUZON-HL09

B. Hanging installation

①

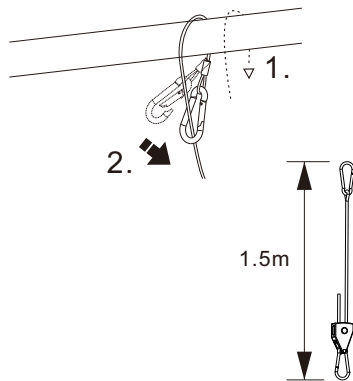

②

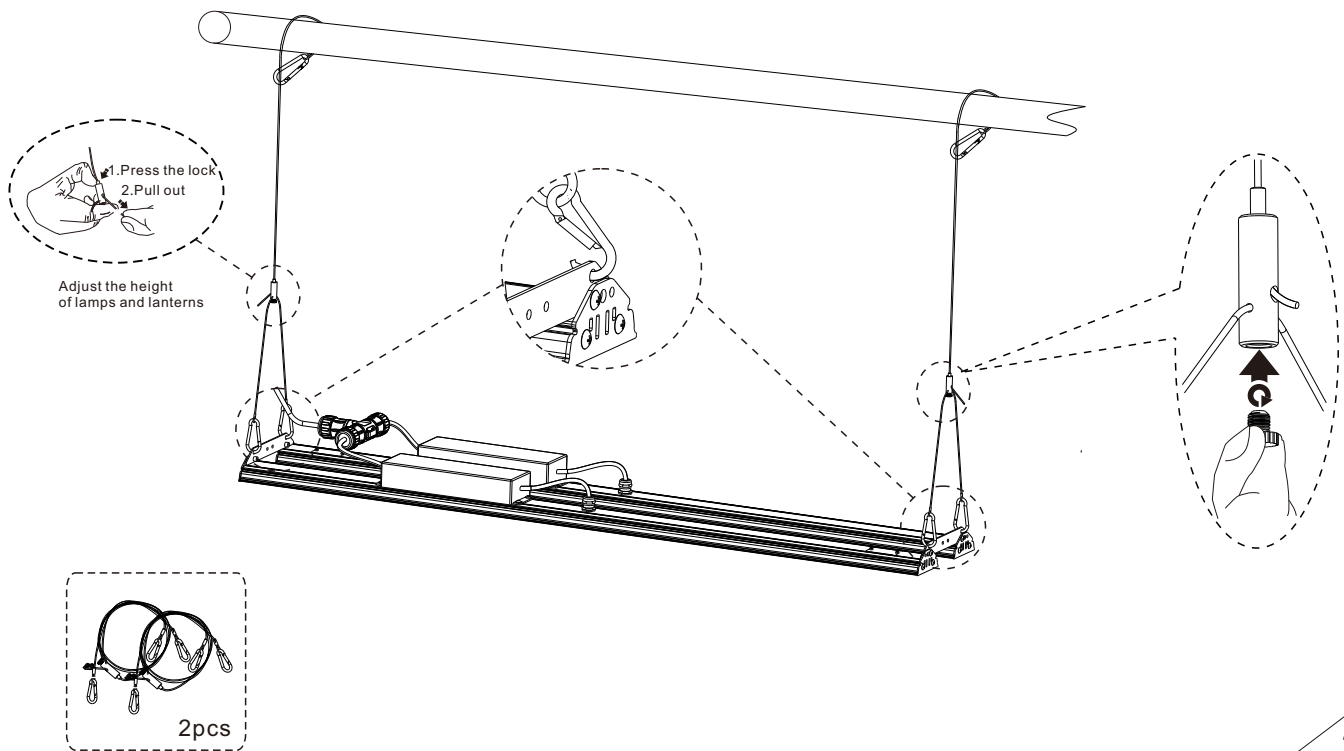
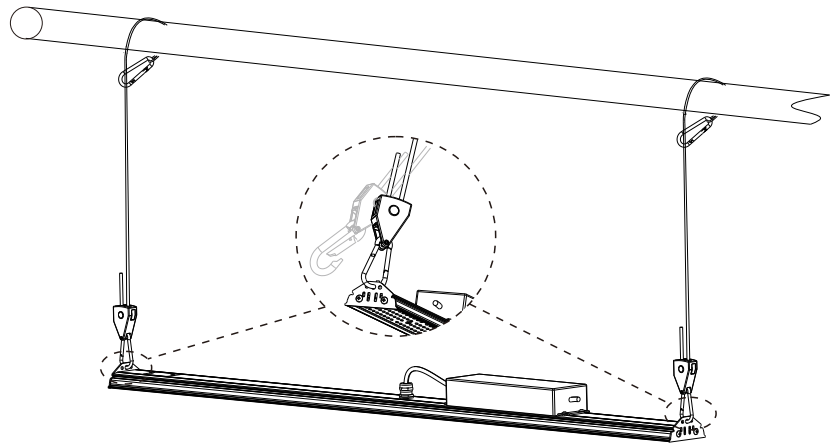

2

L	brown	black
N	blue	white
⊕ GND	yellow/green	green

Dimmable

DIM+ / DA1	blue	brown	purple	white
DIM- / DA2	white	blue	gray	black

•if the external flexible cable or cord of this luminaire is damaged, it shall be exclusively replaced by the manufacturer or his service agent or a similar qualified person in order to avoid a hazard.

3