



wireless transmission
technology



Technical Application
Guide for
LED Ceiling light
AL02-14-25W-AW

Introduction



AL02 Oyster LED ceiling light can be controlled by 2.4G wireless remote controller, offering dimmable, color changeable (controlled by remote controller /switch), power off memory and timing switch functions etc.

The light color can be adjusted from warm white to cold white, from dark to bright. The ceiling light will keep the memory in the last lighting mode (light color and brightness) when in OFF situation over 10 seconds. Timing switch function brings personalized energy-saving experience. Low power consumption, fast switch between different functions, excellent stability and strong anti-interference capacity make this lamp outstanding.

- Up to 70% energy saving compared to standard CFL
- Long lifetime of 40,000 hours
- Dimmable when using 2.4G remote controller
- Color changeable. (Controlled by remote controller or by switch)
- Power off memory: The lamp will be the same brightness and color when it's on after power off or it's turned off more than 10 seconds.
- 120° wide beam angle
- CCT: 2700K~5700K
- No UV/IR light
- Environment friendly, without Mercury or any other hazardous substances

Application notes

- IP20 for indoor use
- Professional electrician for installation only
- Switch off before installation
- Do not touch when in use
- Keep away from hot steam and corrosive gas

Application Areas

Suitable for commercial and residential applications like office, supermarket, shop, school, hotel, restaurant, workshop, warehouse, home etc.

Certificate



Product Information

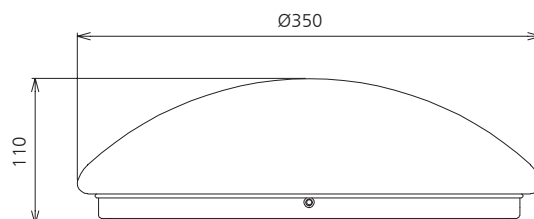

Technical Specifications

Model	Voltage	Power	Power Factor	Lumen (±5%)	Beam angle	CCT	Lifespan	CRI	Dimmable	Dimension
AL02-14-25W-AW	AC100-240V	25W	≥0.9	0~1680	120°	2700~5700K	40000h	≥80	Yes	Ø350*110mm

Driver data Sheet

Driver data	DIM
Input rated Voltage	AC100-240V
Frequency	50/60Hz
Input Voltage	AC85-265V
Efficiency	≥85%
Total load Wattage	25W±5%
Power Factor	≥0.9
Rated input current	≤0.3A
Full load output Voltage	DC24-38V
Rated output current	600mA
Power tolerance	±5%
Current output tolerance	±5%
Dimming range	5%-100%
Dimmer	2.4G.RF
Short circuit protection	PASS
Over voltage protection	PASS
Over temperature protection	PASS
Withstand voltage	AC1500V

Fixture Compatibility

Rated Wattage	Electrical Classification	Ingress Protection	Operating Temp	Operating Humidity	Storage Temp
25W	I	IP20	-20°C~45°C	0~90%	-20°C~65°C

Spectral Distribution

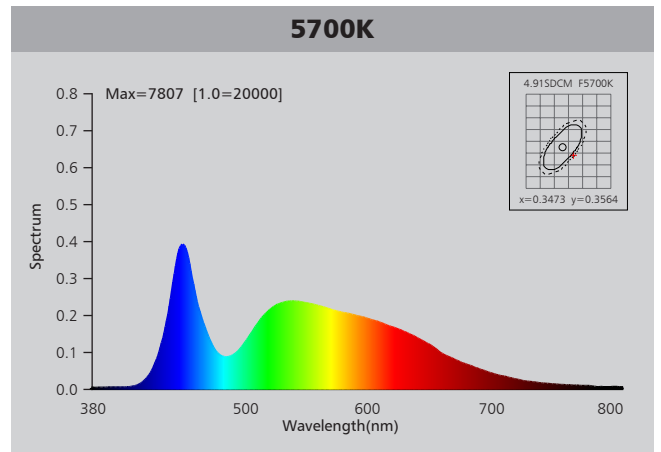
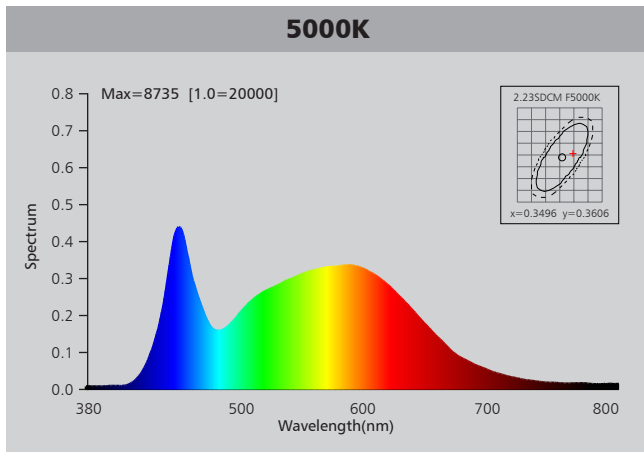
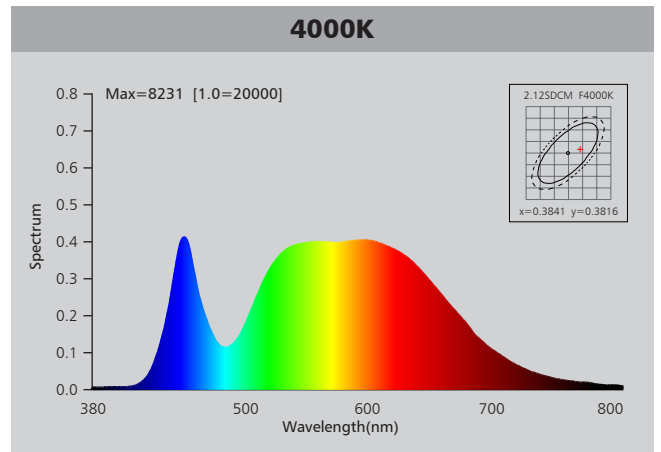
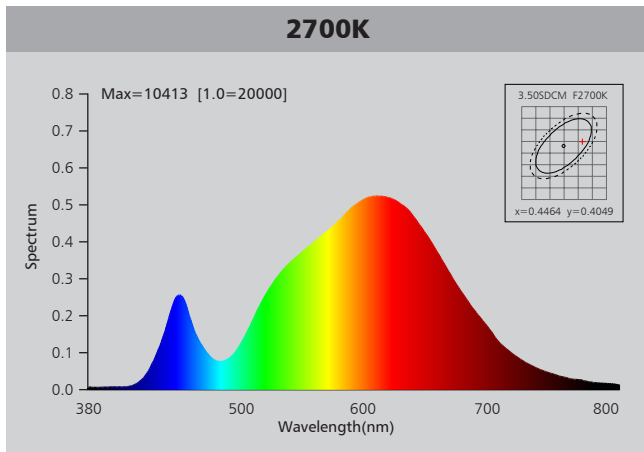

Photometric Diagram

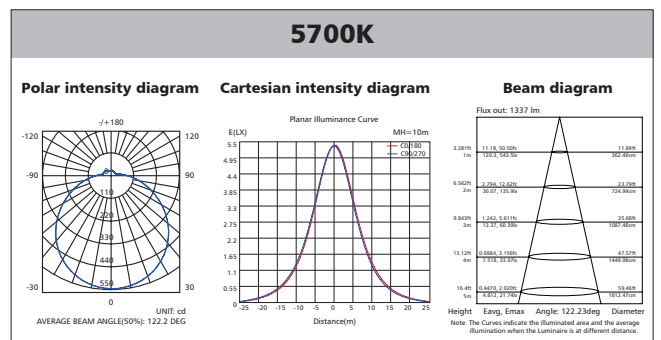
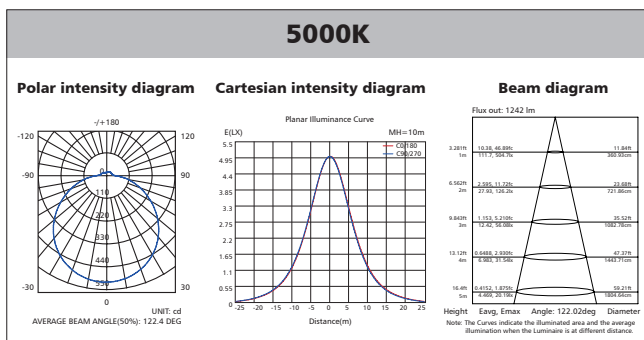
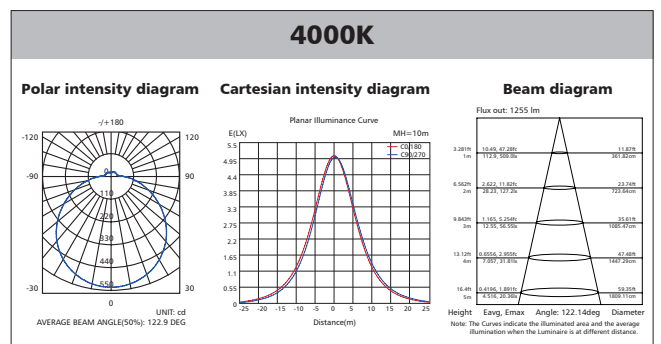
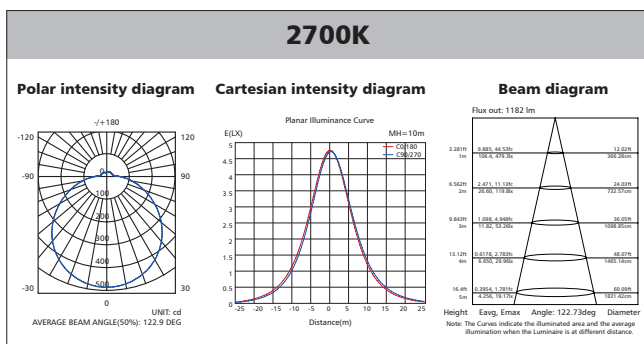

Polar Diagram Comparison

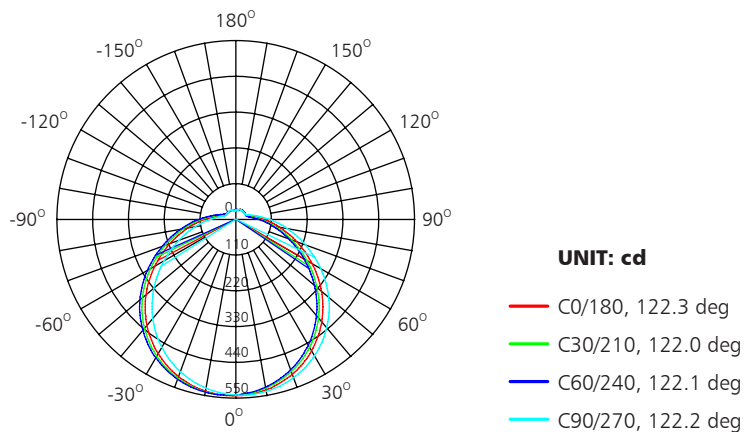

AVERAGE BEAM ANGLE (50%): 122.2DEG



Driver lifetime & LED light decay rate

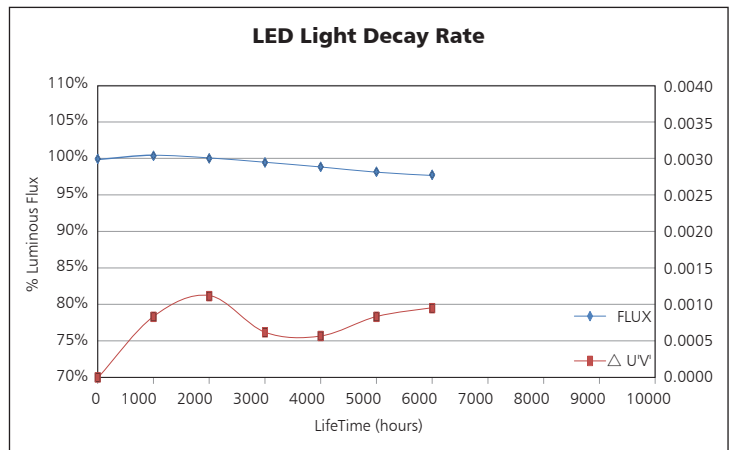
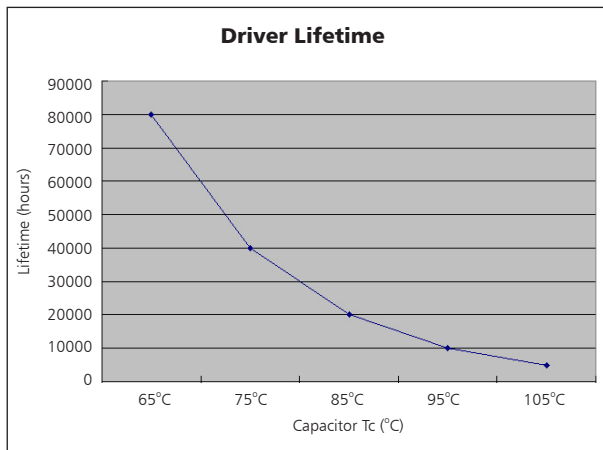

Temperature

- The testing is operated at 25°C
- The lifetime of capacitor, minimum of 5,000 hours if operated at 105°C, will be doubled whenever the temperature drops 10°C
- The highest withstand temperature of IC, MOS could be 120°C
- The highest withstand temperature of LED junction temperature is 150°C

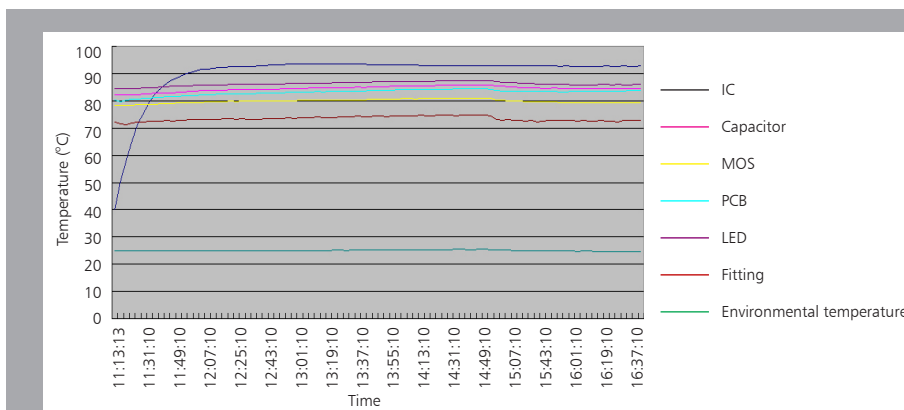

The driver lifespan is based on capacitor working temperature.



Adopting 2.4 G high frequency wireless remote control, this light enjoys the characters of low power consumption, far transmission distance, strong anti-interference capacity, high communication rate. It can be used as night light, the lamp enjoy the memory function. (when the light was turned off, it will memorize the brightness before you turn off)

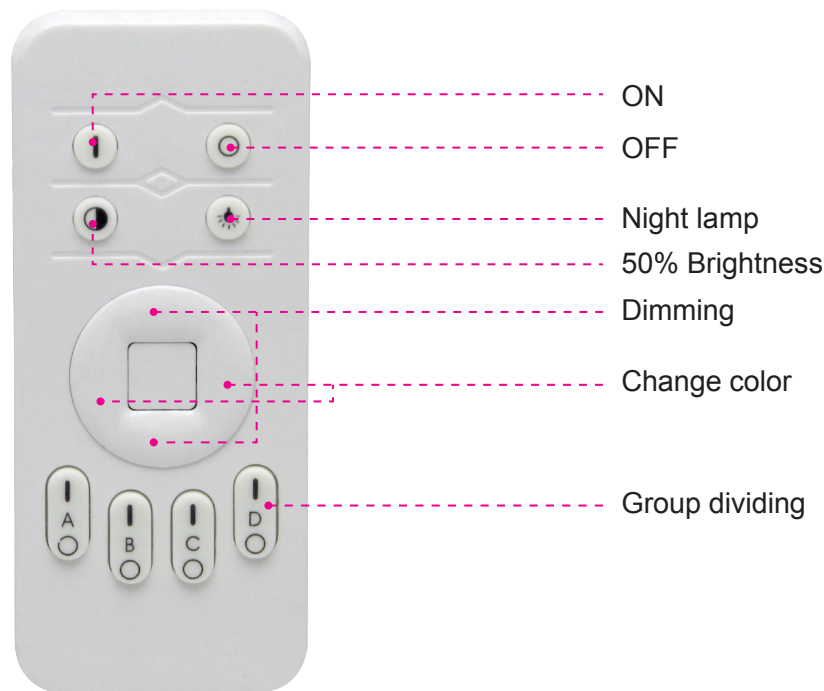



Code Matching and grouping: (only they are code matched with each other can the lamp be controlled remotely)

- Select the lamp need to be conducted with grouping control; after turning off the power for 10 seconds, turn on the power again; in this moment (within 3 seconds), press the "Group On" button (); the lamp will flash for 3 times to confirm the matching and grouping is done.
- Repeat the steps above until all the lamps are matched and grouped.
- Only after this step, the function as below can be set up (color control, light control, timing and night lamp).



Clear code and Re-grouping: (disconnect the led lamp and remote controller to cancel the remote control)

- Cut off the power supply for 10 seconds and switch on again, at the moment it's switched on, press "group on" button () 5 times in a row, then the lamp with quick flashing 6 times which predict the success of code cleaning.
- Repeat the step of group code matching can work for LED lights again.

Synchronous and Re-grouping control: (for light dimming and colour changeable)

- Synchronous Press Full "ON" button () enter into Synchronous set mode, press each function button to control all groups of LED lamp processing light dimming, colour changeable, timing and night lamp function at the same time.
- Re-grouping Press "group on" button () enter into re-grouping set mode, press each function button to control LED lamp in one single group processing light dimming, colour changeable, timing and night lamp function at the same time.

Turn-off timing function:

- With keeping normal power "on" position, long-press full "ON" button (). After the lamp's quick flashing, press the timing length button within 3 seconds, then the lamp will flash 1-4 times in line with duration which predict the timing success.
- To cancel the timing function, press full "OFF" button () Arst, then turn them back on.

50% brightness function:

- Press "50% brightness" button (), all LED lamps controlled by this controller will turn into 50% brightness mode.
- Press any button on this remote controller can exit from this mode.

Night lamp function: (for all groups)

- Press "Night light" button (), all LED lamps controlled by this controller enter into night light mode, the light brightness can reach at 2‰ of the maximum brightness.
- Press any button on this remote controller can exit from this mode.

Night lamp function: (For separate group)

- With keeping normal power on, long-press full "OFF" button () in separate group at least 2 seconds, the corresponding LED lamp enters into night light mode, the light brightness can reach at 2‰ of the maximum brightness.
- Press any button on this remote controller can exit from this mode.
Grouping control: (remote controller makes several-for -one or one-for-several control possible with LED lamp)
- Keep the original mode, Cut off the power supply for 10 seconds and switch on again, use another remote controller operating grouping code within 3 seconds. Then the LED lamp sets can be controlled by other remote controller.
- Cut off the power supply for 10 seconds and switch on again, use same remote controller operating grouping code within 3 seconds. Then different group of LED lamp sets can be controlled by same remote controller.

Memory Function:

- The lamp will be the same brightness and color when it's on after power off or it's turned off.

You can set 4 different lighting situations (warm white, cold white, daylight white and sleep/night light) by switching your light switch on and off (the light must remain switched off for at least one second). The lamp has a memory function so that the lighting / dimming situation that you last set will automatically occur when you next activate the lamp. (However, the light must remain switched off for at least 10 seconds)

Installation (US)

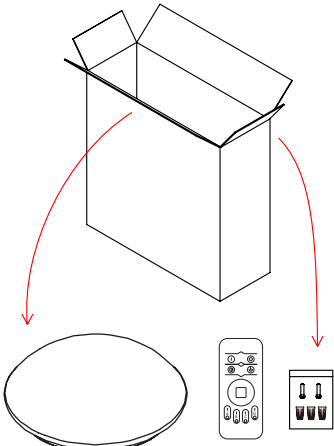
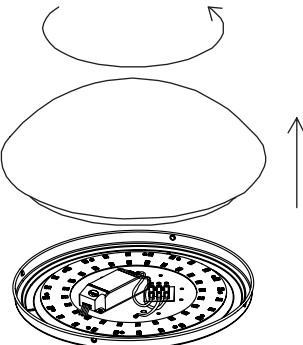
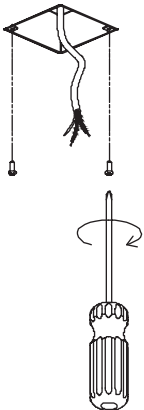
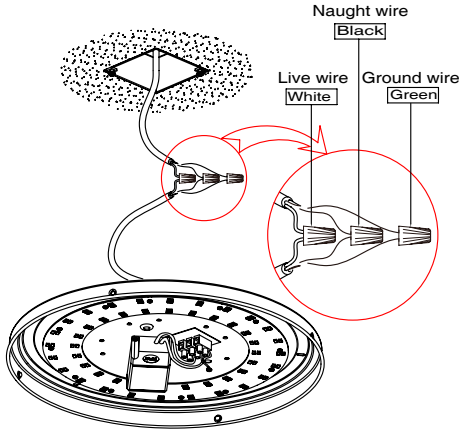
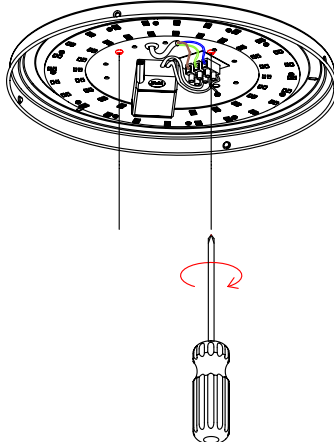
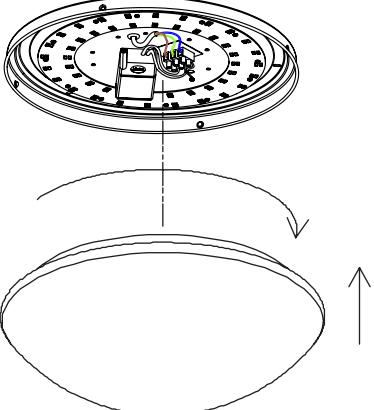
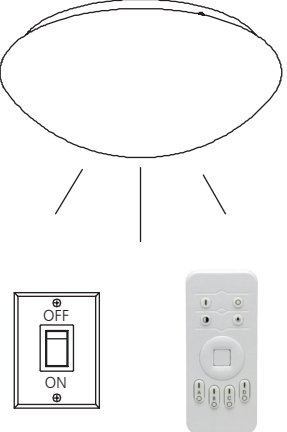
 <p>Unbox ceiling light and accessory pack. 1</p>	 <p>Rotate to separate lamp shade and base plate. 2</p>	 <p>Fix screw on junction box. 3</p>
 <p>Switch off, wiring "live", "Neutral" and "Ground" by terminal cap respectively. 4</p>	 <p>Surface mount the base plate to ceiling by fasten screw. 5</p>	
 <p>Rotate to unite the lamp shade and the base plate. 6</p>	 <p>Finish 7</p>	

Installation (EU)

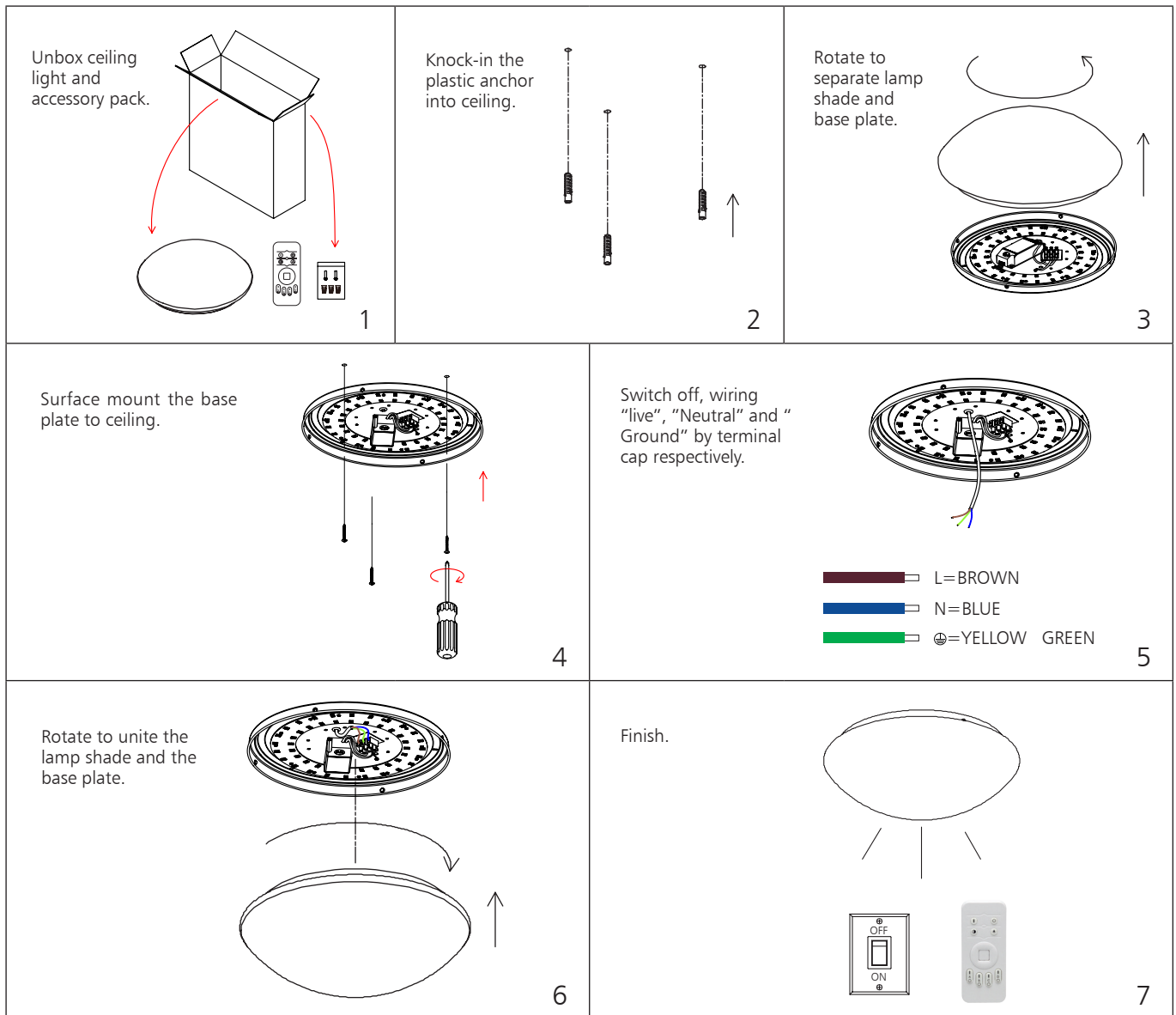

Packaging Information

	SIZE(CM)	N.W/pc (KGS)	G.W.(KGS)	Q'TY(PCs)
Carton	75*40*41	1.1	7	5

	CTNS	Q'TY(PCs)	VOLUME(CBM)
20" standard container	210	1050	28
40" standard container	420	2100	56

