



Technical Application
Guide for LED
Ceiling light
AL02-11-15W-A

Introduction



Oystar ceiling light adopts high lumen SMD LED, PC diffuser with even light output. High PF LED driver with Triac dimmable function, 120° wide beam angle.

- Up to 70% energy saving compared to standard CFL
- Long lifetime of 40,000 hours
- Dimmable when using triac dimmer
- 120° wide beam angle
- CCT: 3000K 4000K
5000K 5700K
- No UV/IR light
- Environment friendly, without Mercury or any other hazardous substances

Application notes

- IP20 for indoor use
- Professional electrician for installation only
- Switch off before installation
- Do not touch when in use
- Keep away from hot steam and corrosive gas

Application Areas

Suitable for commercial and residential applications like office, supermarket, shop, school, hotel, restaurant, workshop, warehouse, home etc.

Certificate

CE **RoHS** **SAA**



Product Information

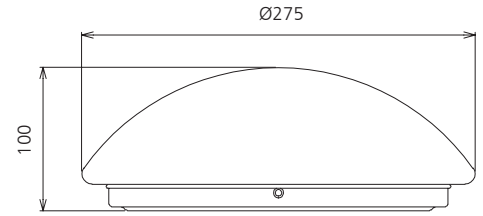

Technical Specifications

Model	Voltage	Power	Power Factor	Lumen (±5%)	Beam angle	CCT	Lifespan	CRI	Dimmable	Dimension
AL02-11-15W-A	AC100-240V	15W	≥0.9	1050	120°	3000K	40000h	≥80	No	Ø275*100mm
AL02-11-15W-A	AC100-240V	15W	≥0.9	1170	120°	4000K	40000h	≥80	No	Ø275*100mm
AL02-11-15W-A	AC100-240V	15W	≥0.9	1220	120°	5000K	40000h	≥80	No	Ø275*100mm
AL02-11-15W-A	AC100-240V	15W	≥0.9	1250	120°	5700K	40000h	≥80	No	Ø275*100mm
AL02-11-15WD-A	AC120V AC230V	15W	≥0.9	1000	120°	3000K	40000h	≥80	Yes	Ø275*100mm
AL02-11-15WD-A	AC120V AC230V	15W	≥0.9	1100	120°	4000K	40000h	≥80	Yes	Ø275*100mm
AL02-11-15WD-A	AC120V AC230V	15W	≥0.9	1160	120°	5000K	40000h	≥80	Yes	Ø275*100mm
AL02-11-15WD-A	AC120V AC230V	15W	≥0.9	1180	120°	5700K	40000h	≥80	Yes	Ø275*100mm

Driver data Sheet

Driver data	DIM	DIM	Non-dim
Input rated Voltage	AC120V	AC230V	AC100-240V
Frequency	60Hz	50Hz	50/60Hz
Input Voltage	AC90-140V	AC200-240V	AC85-265V
Efficiency	≥78%	≥78%	≥85%
Total load Wattage	15W±1W	15W±1W	15W±1W
Power Factor	≥0.9	≥0.9	≥0.9
Rated input current	≤0.14A	≤0.08A	≤0.17A
Full load output Voltage	DC25-30V	DC25-30V	DC25-30V
Rated output current	430mA	430mA	460mA
Output current range	430mA±5%	430mA±5%	460mA±5%
Power tolerance	±5%	±5%	±5%
Current output tolerance	±5%	±5%	±5%
Dimming range	8%-100%	8%-100%	—
Dimmer	Triac dimmers	Triac dimmers	—
Short circuit protection	PASS	PASS	PASS
Over voltage protection	PASS	PASS	PASS
Over temperature protection	PASS	PASS	PASS
Withstand voltage	AC1500V	AC1500V	AC1500V

Fixture Compatibility

Rated Wattage	Electrical Classification	Ingress Protection	Operating Temp	Operating Humidity	Storage Temp
15W	I	IP20	-20°C~45°C	0~90%	-20°C~65°C

Spectral Distribution

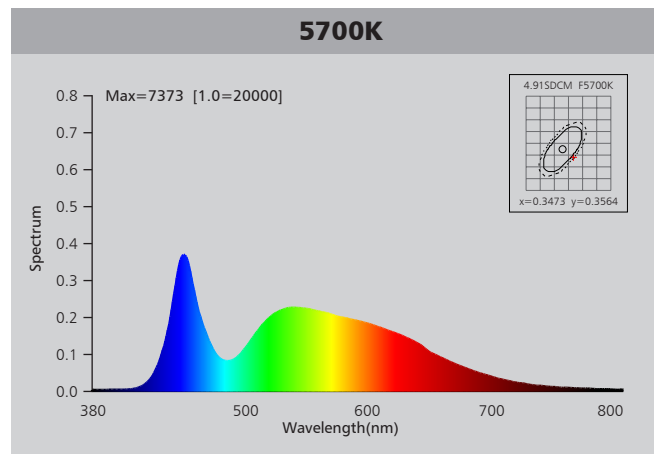
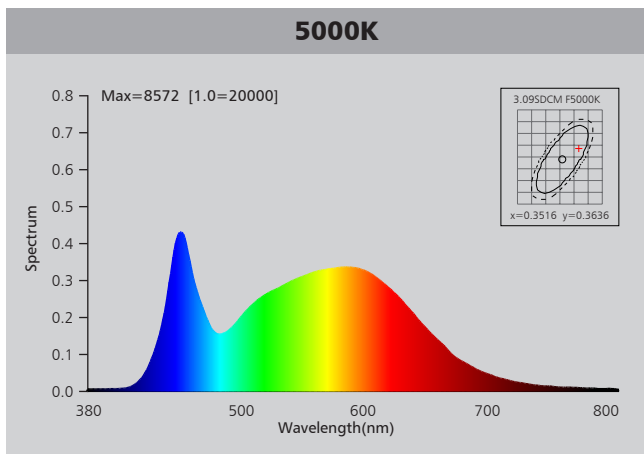
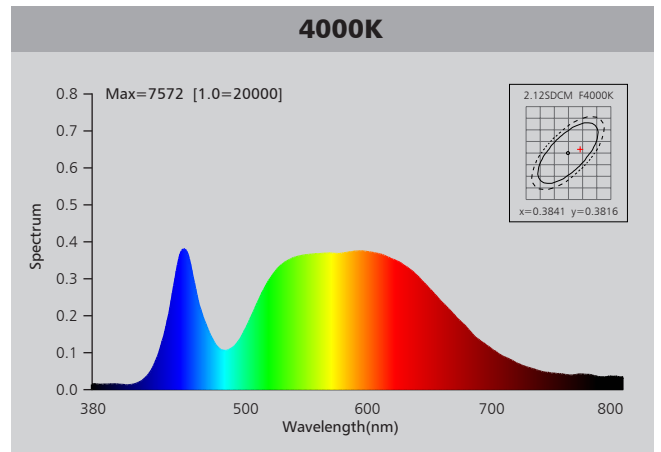
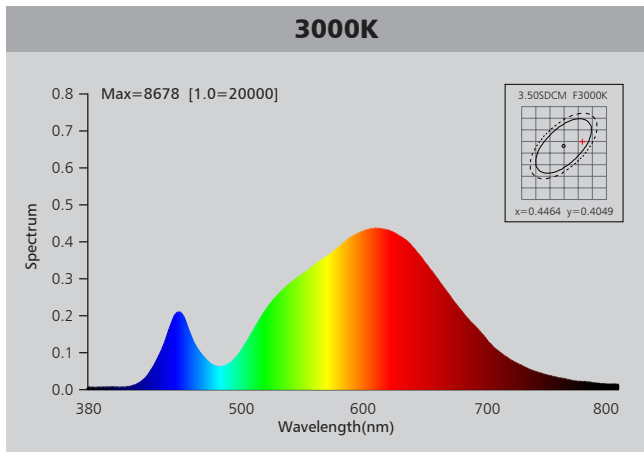

Photometric Diagram

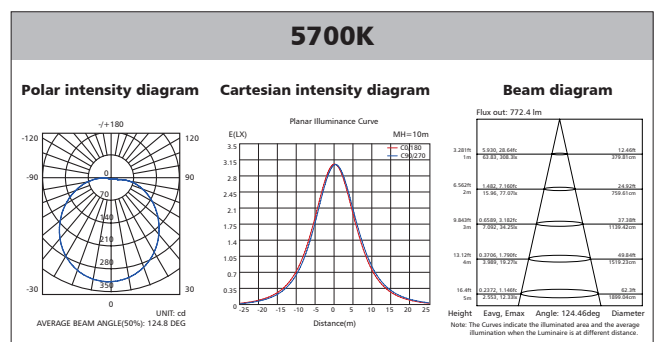
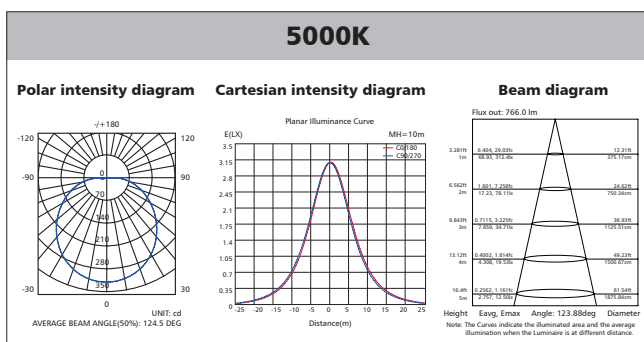
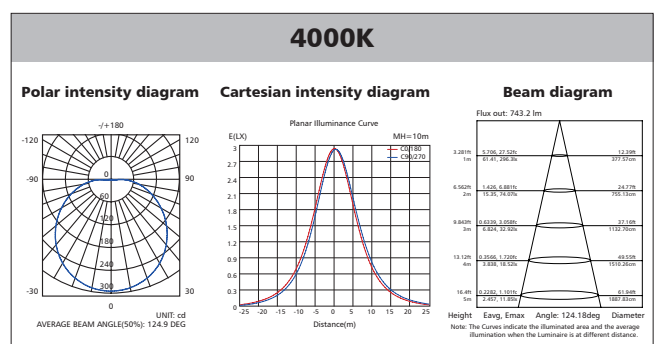
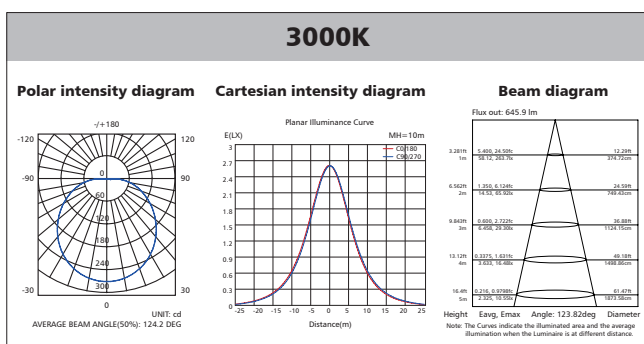

Polar Diagram Comparison

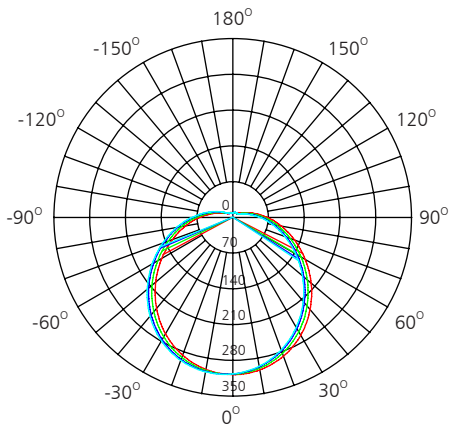

UNIT: cd

- C0/180, 124.8 deg
- C30/210, 124.9 deg
- C60/240, 124.8 deg
- C90/270, 124.6 deg



AVERAGE BEAM ANGLE (50%): 124.8DEG

Driver lifetime & LED light decay rate

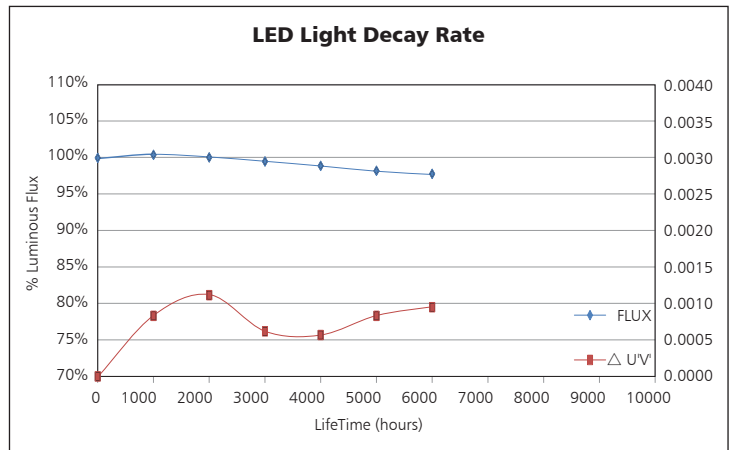
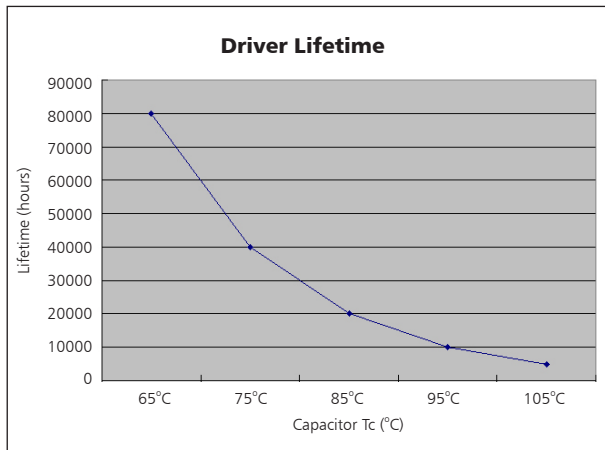

Temperature

- The testing is operated at 25°C
- The lifetime of capacitor, minimum of 5,000 hours if operated at 105°C, will be doubled whenever the temperature drops 10°C
- The highest withstand temperature of IC, MOS could be 120°C
- The highest withstand temperature of LED junction temperature is 150°C

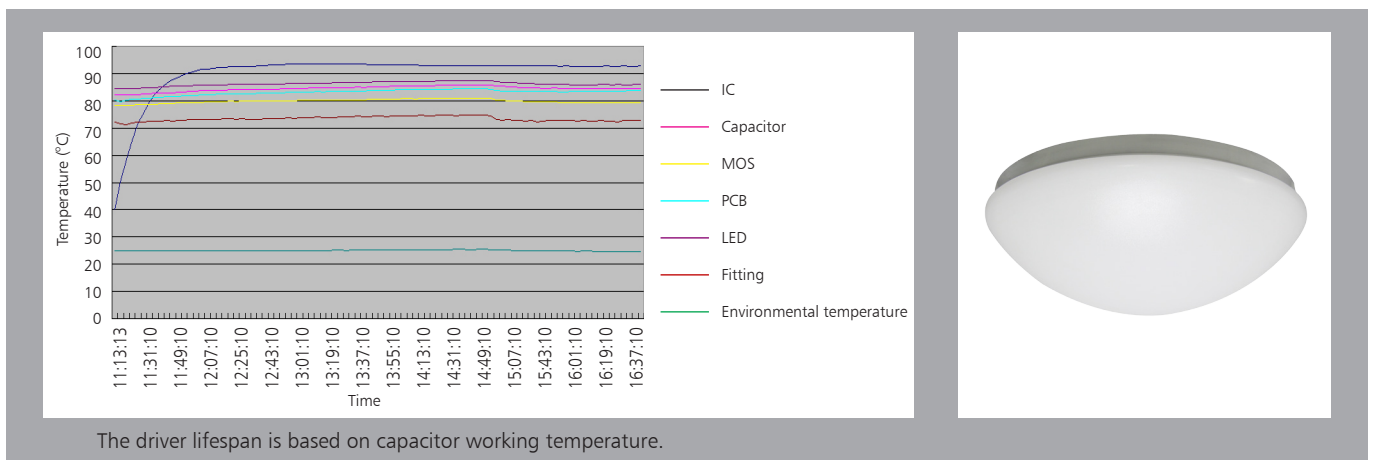



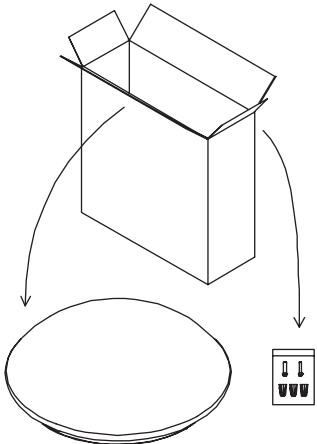
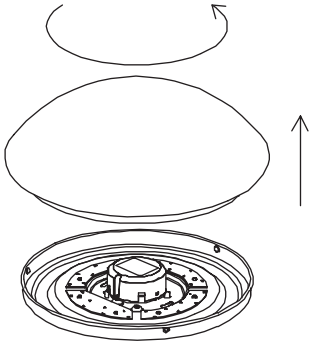
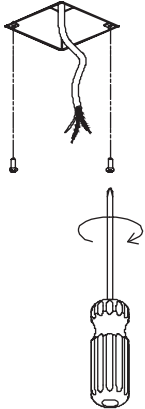
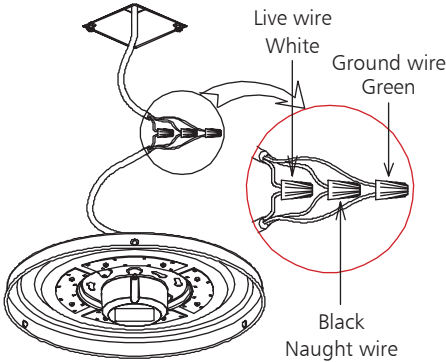
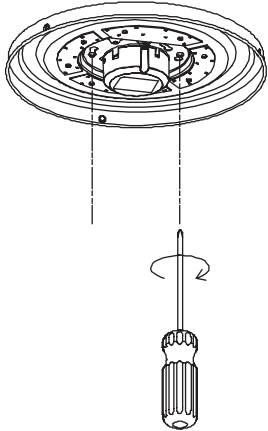
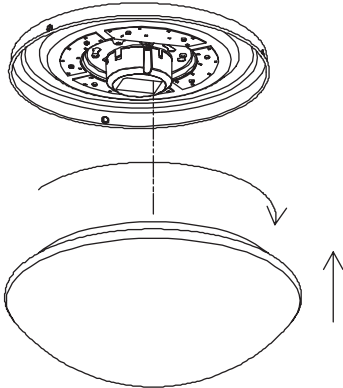
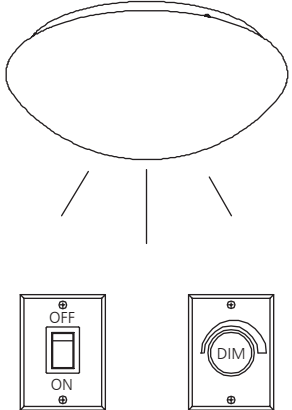

The driver lifespan is based on capacitor working temperature.

Installation (US)

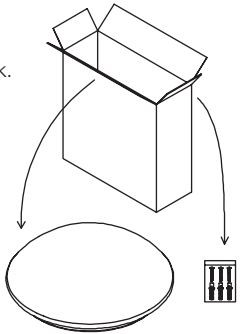
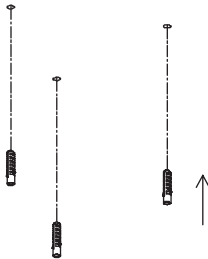
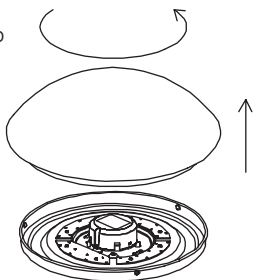
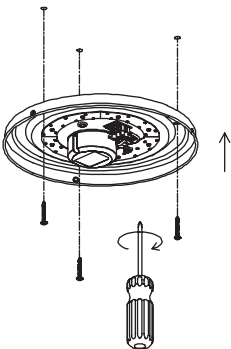
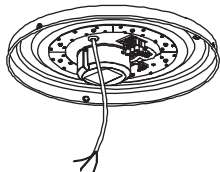
 <p>Unbox ceiling light and accessory pack. 1</p>	 <p>Rotate to separate lamp shade and base plate. 2</p>	 <p>Fix screw on junction box. 3</p>
 <p>Switch off, wiring "live", "Neutral" and "Ground" by terminal cap respectively. 4</p>	 <p>Surface mount the base plate to ceiling by fasten screw. 5</p>	
 <p>Rotate to unite the lamp shade and the base plate. 6</p>	 <p>Finish 7</p>	

Installation (EU)

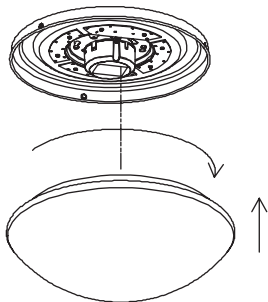
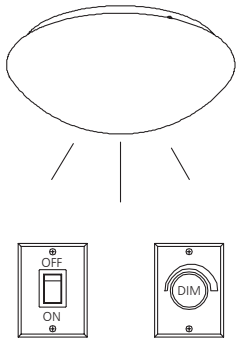
<p>Unbox ceiling light and accessory pack.</p>  <p>1</p>	<p>Knock-in the plastic anchor into ceiling.</p>  <p>2</p>	<p>Rotate to separate lamp shade and base plate.</p>  <p>3</p>
<p>Surface mount the base plate to ceiling.</p>  <p>4</p>	<p>Switch off, wiring "live", "Neutral" and "Ground" by terminal cap respectively.</p>  <p>5</p> <ul style="list-style-type: none">  L=BROWN  N=BLUE  ⊕=YELLOW GREEN 	
<p>Rotate to unite the lamp shade and the base plate.</p>  <p>6</p>	<p>Finish.</p>  <p>7</p>	

Packaging Information

	SIZE(CM)	N.W/pc (KGS)	G.W.(KGS)	Q'TY(PCs)
Carton	73*35*36	0.76	5	5

	CTNS	Q'TY(PCs)	VOLUME(CBM)
20" standard container	274	1370	28
40" standard container	549	2745	56

