



Technical Application

LED Spotlight

LUZ-TL15-30W

# Introduction



multi head track light adopts COB LEDs with excellent color rendering index to increase the color fidelity of the target illuminated object. Surface mount or recessed installation provided for various applications. Aluminum body provides excellent heat dissipation, even light output without glare & dark spot. Adjustable lighting orientation with 360 degree in horizontal direction and 90 degree in vertical direction provided.

- Up to 70% energy saving compared to standard CFL
- Long lifetime of 40,000 hours
- 24°/36°/45°/60° beam angle
- CCT: 2700K 3000K  
4000K 5000K
- No UV/IR light
- Environment friendly, without Mercury or any other hazardous substances

## Application notes

- IP20 for indoor use only
- Professional electrician for installation only
- Switch off before installation
- Do not touch when in use
- Keep away from hot steam and corrosive gas

## Application Areas

It is suitable for supermarket, specialty store, show window, exhibition hall; focus lighting, decorative and background lighting, where attention is focused on subjects to emphasize special visual points.

## Certificate

**CE** **RoHS**



# Product Information

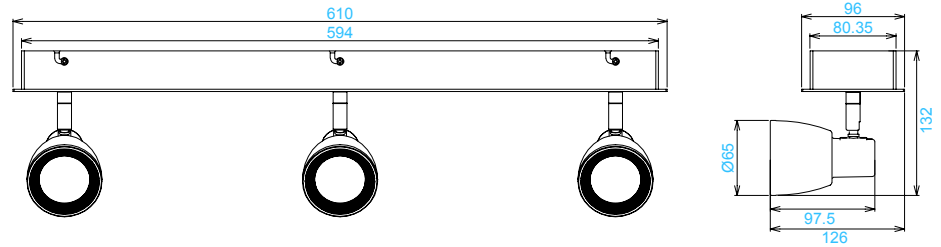

## Technical Specifications

Model	Voltage	Power	Power Factor	Lumen (±5%)	Beam angle	CCT	Lifespan	CRI	Dimmable	Dimension
LUZ-TL15-30W	AC100-240V	30W	≥0.9	2250	24°/36°/45°/60°	2700K	40000h	≥80	No	610*126*132mm
LUZ-TL15-30W	AC100-240V	30W	≥0.9	2300	24°/36°/45°/60°	3000K	40000h	≥80	No	610*126*132mm
LUZ-TL15-30W	AC100-240V	30W	≥0.9	2400	24°/36°/45°/60°	4000K	40000h	≥80	No	610*126*132mm
LUZ-TL15-30W	AC100-240V	30W	≥0.9	2350	24°/36°/45°/60°	5000K	40000h	≥80	No	610*126*132mm
LUZ-TL15-30W-D	AC230V	30W	≥0.9	2120	24°/36°/45°/60°	2700K	40000h	≥80	Yes	610*126*132mm
LUZ-TL15-30W-D	AC230V	30W	≥0.9	2150	24°/36°/45°/60°	3000K	40000h	≥80	Yes	610*126*132mm
LUZ-TL15-30W-D	AC230V	30W	≥0.9	2250	24°/36°/45°/60°	4000K	40000h	≥80	Yes	610*126*132mm
LUZ-TL15-30W-D	AC230V	30W	≥0.9	2210	24°/36°/45°/60°	5000K	40000h	≥80	Yes	610*126*132mm

## Driver data Sheet

Driver data	DIM	Non-dim
Input rated Voltage	AC230V	AC100-240V
Frequency	50HZ	50/60Hz
Input Voltage	AC200-240V	AC85-265V
Efficiency	≥80%	≥85%
Total load Wattage	30W±5%	30W±5%
Power Factor	≥0.9	≥0.9
Rated input current	≤0.18A	≤0.36A
Full load output Voltage	DC35-38V	DC35-38V
Rated output current	680mA	700mA
Output current range	680mA±5%	700mA±5%
Power tolerance	±5%	±5%
Current output tolerance	±5%	±5%
Dimming range	8%-100%	----
Dimmer	Triac dimmers	----
Short circuit protection	PASS	PASS
Over voltage protection	PASS	PASS
Over temperature protection	PASS	PASS
Withstand voltage	AC1500V	AC1500V

## Fixture Compatibility

Rated Wattage	Electrical Classification	Ingress Protection	Operating Temp	Operating Humidity	Storage Temp
30W	I	IP20	-20°C~45°C	0~90%	-20°C~65°C

# Spectral Distribution

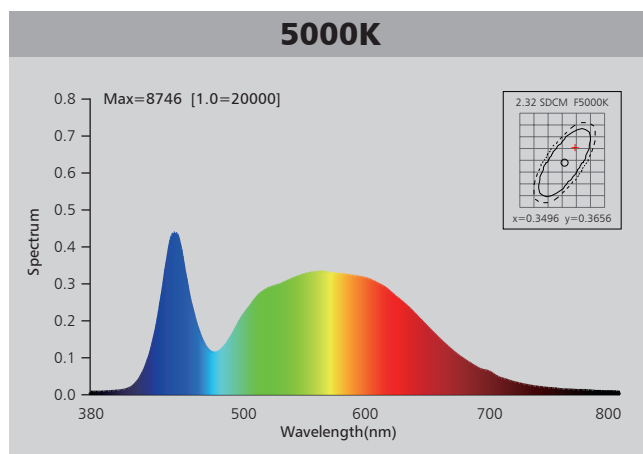
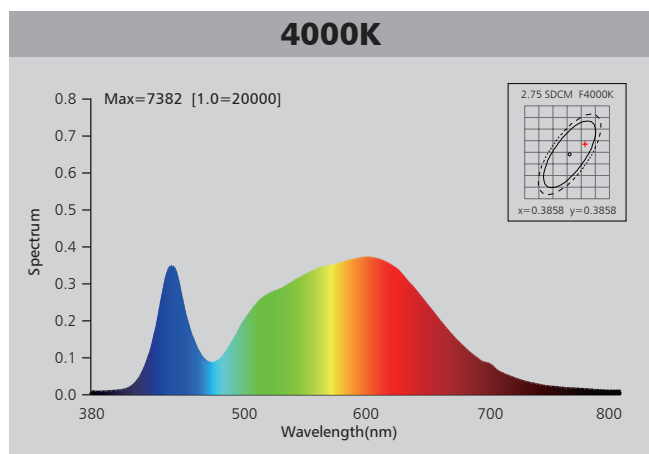
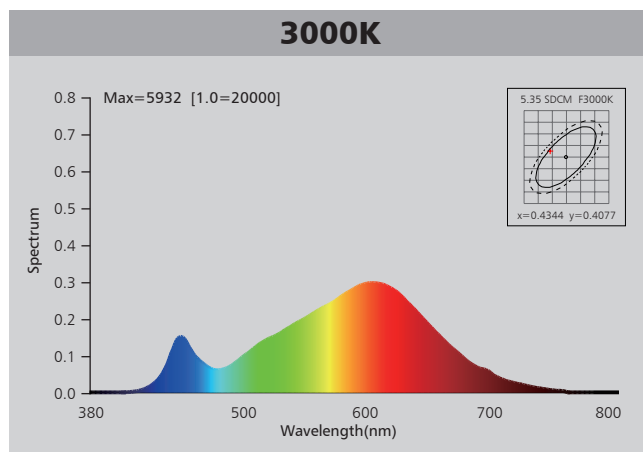
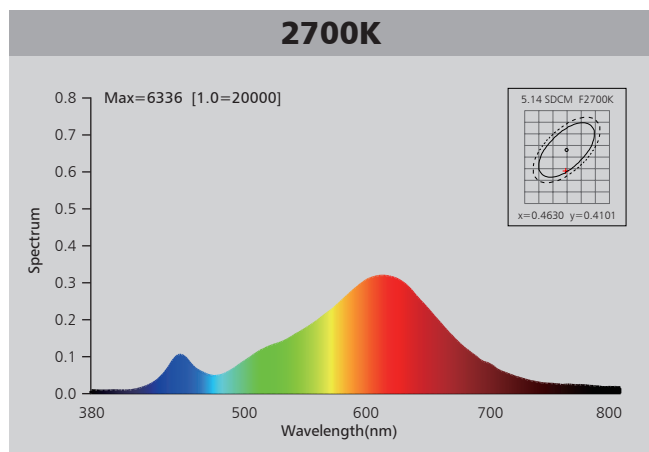

# Photometric Diagram

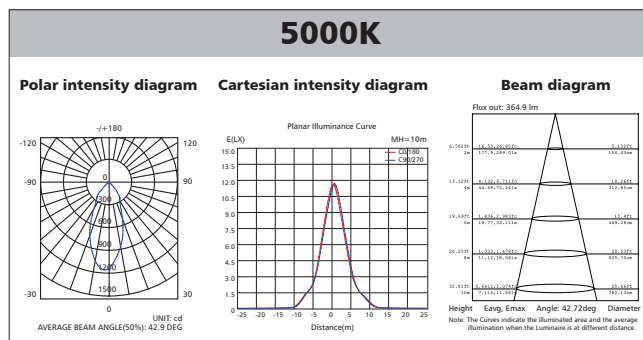
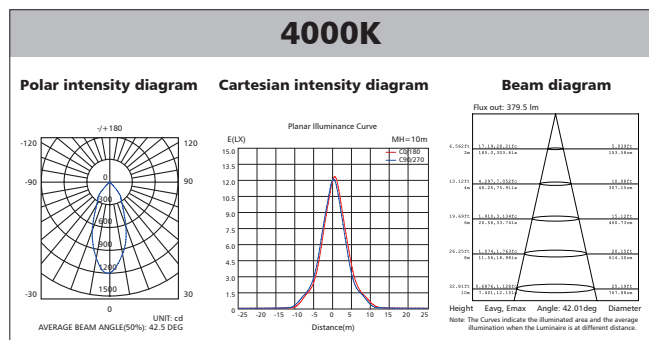
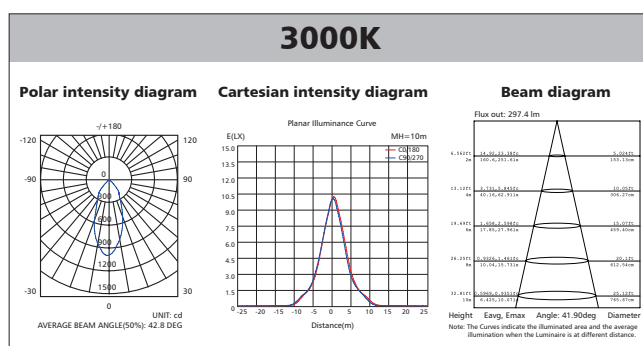
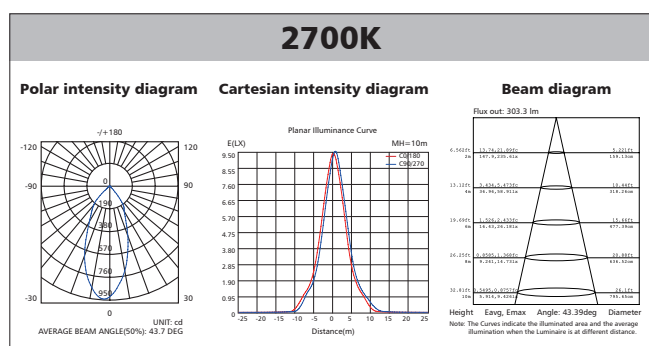

## Polar Diagram Comparison

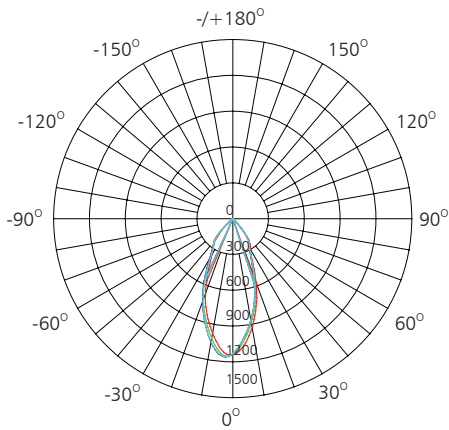

UNIT: cd

- C0/180, 42.8 deg
- C30/210, 43.1 deg
- C60/240, 43.0 deg
- C90/270, 42.8 deg

AVERAGE BEAM ANGLE (50%): 42.9DEG



## Driver lifetime & LED light decay rate

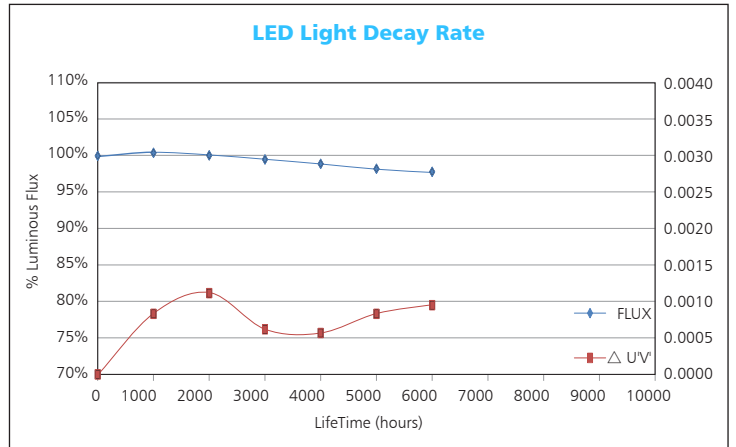
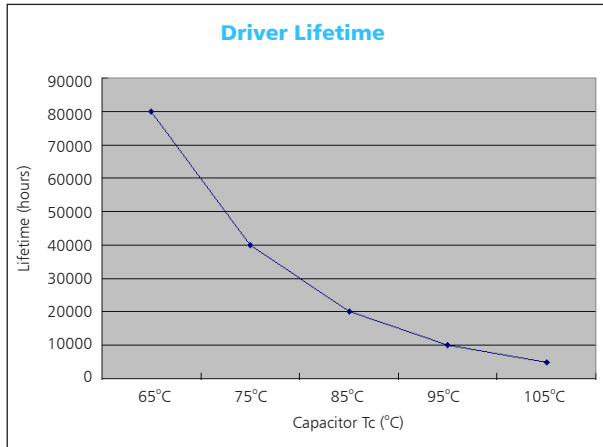

## Temperature

- The testing is operated at 25°C
- The lifetime of capacitor, minimum of 5,000 hours if operated at 105°C, will be doubled whenever the temperature drops 10°C
- The highest withstand temperature of IC, MOS could be 120°C
- The highest withstand temperature of LED junction temperature is 150°C

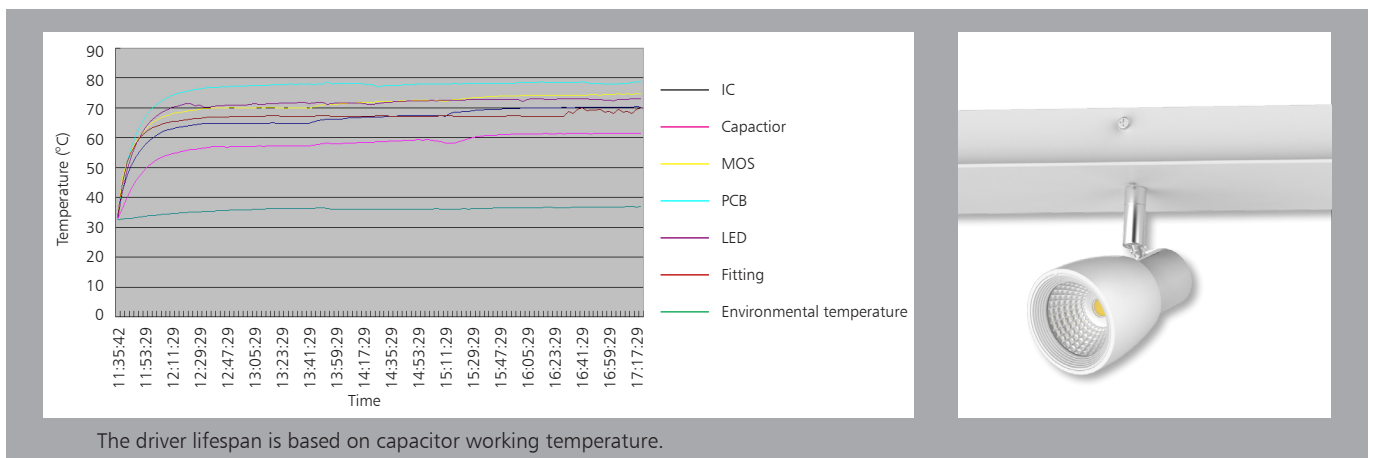

The driver lifespan is based on capacitor working temperature.

## Ceiling mounted installation:

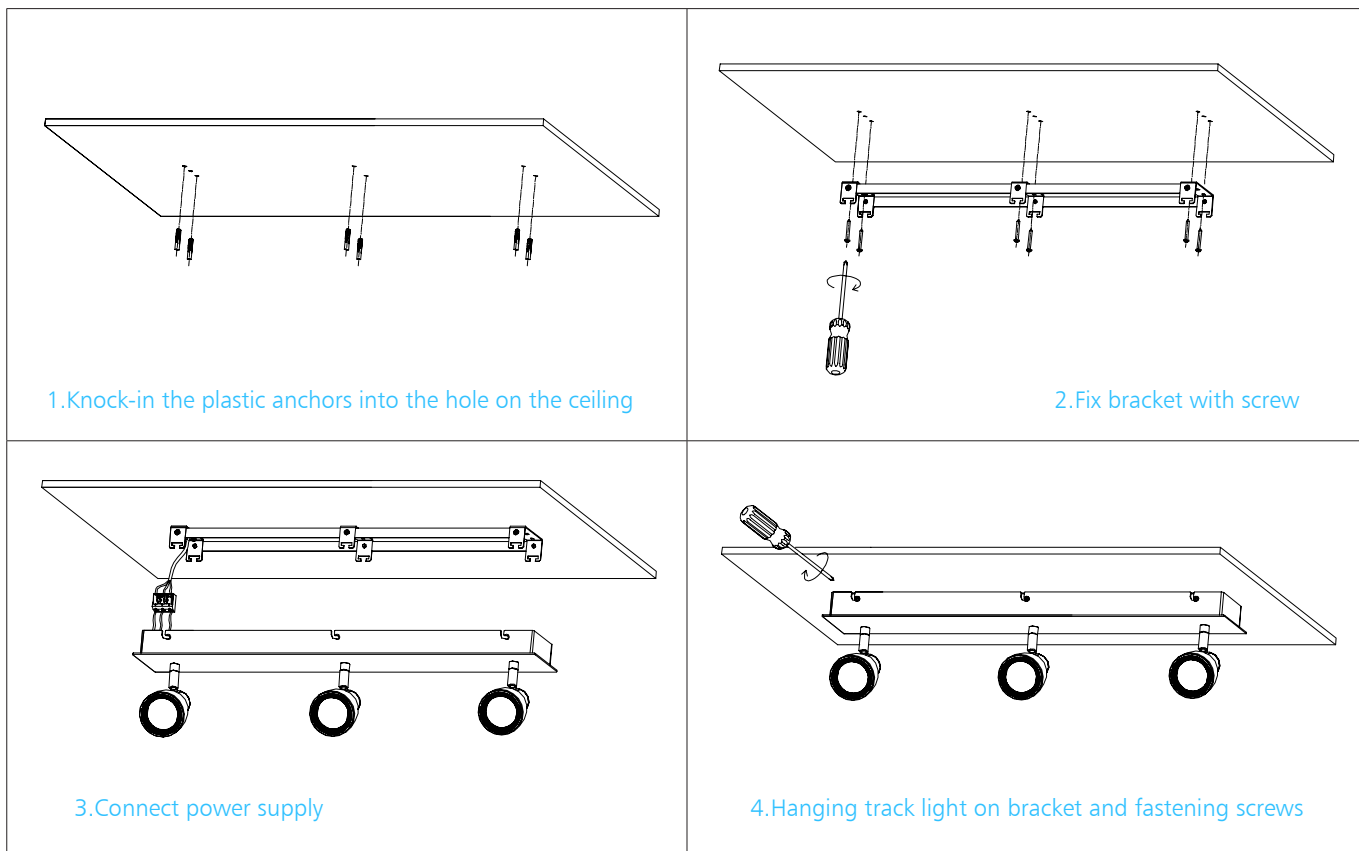

## Embedded installation:

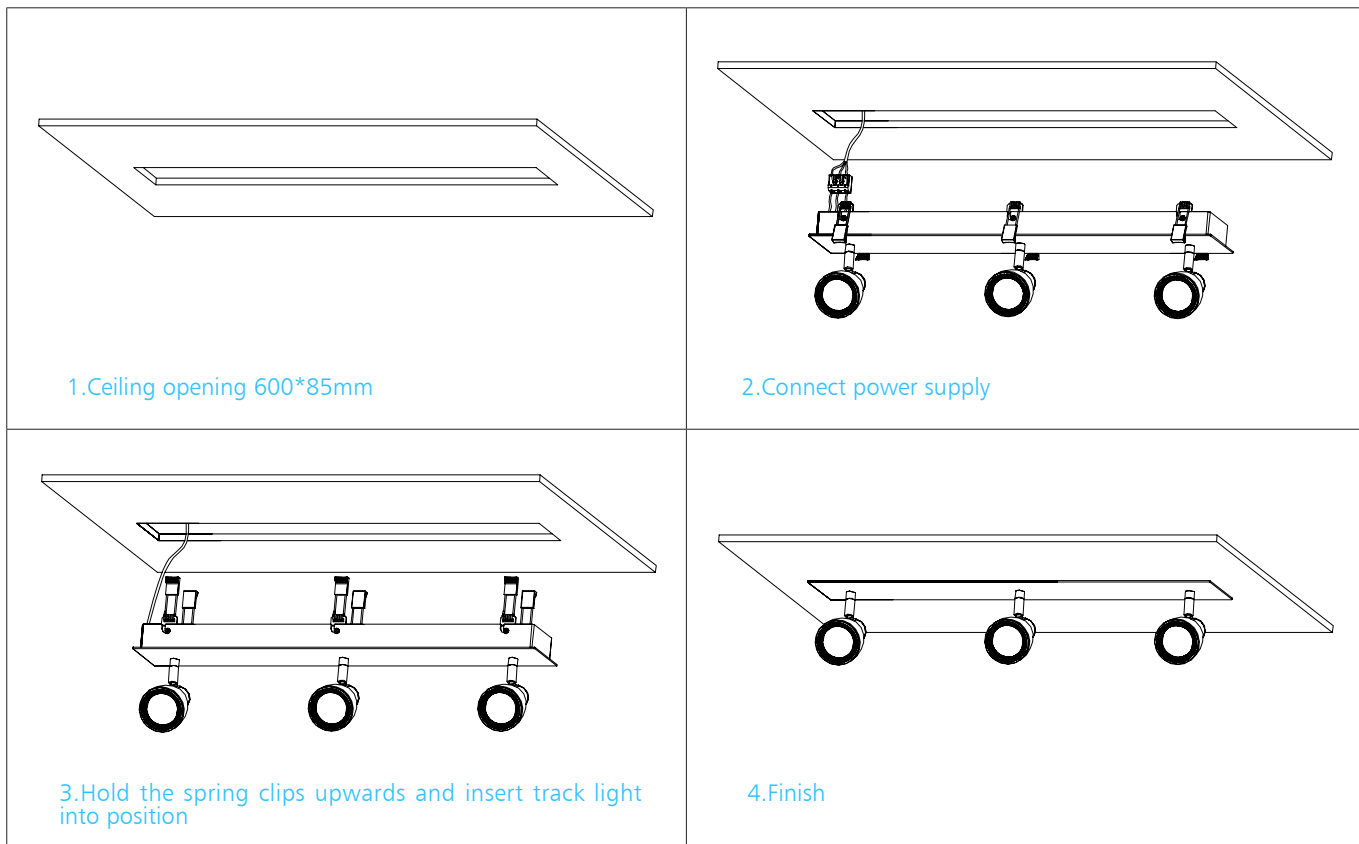

## Packaging Information

	SIZE(CM)	N.W/pc (KGS)	G.W.(KGS)	Q'TY(PCS)
Carton	66.5*44*37	1.7	15	6

	CTNS	Q'TY(PCS)	VOLUME(CBM)
20' standard container	256	1536	28
40' standard container	512	3072	56

