

luzon
lighting™



Technical Application Track Light

LUZ-TL04-10W

Introduction



LUZON track light adopts high efficient reflector and COB LED chip. It is designed with advanced light distribution technology without glare, maximum utilization of light output. Dimmable available for wide choice; surface mounted and embedded installation provided for all possible installation situations.

- Up to 70% energy saving compared to standard CFL
- Long lifetime of 40,000 hours
- Dimmable when using triac dimmer
- 24° 36° beam angle
- CCT: 2700K 3000K
4000K 5000K
- No UV/IR light
- Environment friendly, without Mercury or any other hazardous substances

Application notes

- IP20 for indoor use only
- Professional electrician for installation only
- Switch off before installation
- Do not touch when in use
- Keep away from hot steam and corrosive gas

Application Areas

It is suitable for supermarket, specialty store, show window, exhibition hall; focus lighting, decorative and background lighting, where attention is focused on subjects to emphasize special visual points.

Certificate



RoHS



Product Information

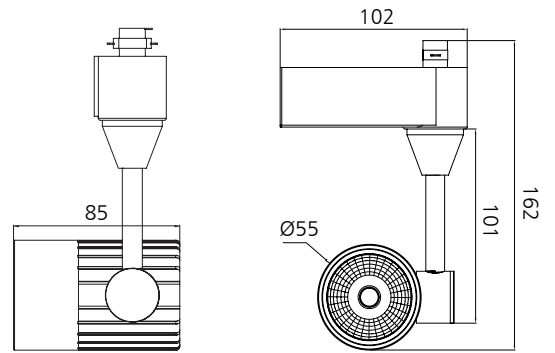

Technical Specifications

Model	Voltage	Power	Power Factor	Lumen (±5%)	Beam angle	CCT	Lifespan	CRI	Dimmable	Dimension
LUZ-TL04-10W	AC230V	10W	≥0.9	650	24°/36°	2700K	40000h	≥80	Yes	162*102*85mm
LUZ-TL04-10W	AC230V	10W	≥0.9	680	24°/36°	3000K	40000h	≥80	Yes	162*102*85mm
LUZ-TL04-10W	AC230V	10W	≥0.9	750	24°/36°	4000K	40000h	≥80	Yes	162*102*85mm
LUZ-TL04-10W	AC230V	10W	≥0.9	700	24°/36°	5000K	40000h	≥80	Yes	162*102*85mm

Driver data Sheet

Driver data	DIM
Input rated Voltage	AC230V
Frequency	50Hz
Input Voltage	AC200-240V
Efficiency	≥80%
Total load Wattage	10W±1W
Power Factor	≥0.9
Rated input current	≤0.06A
Full load output Voltage	DC24-38V
Rated output current	220mA
Output current range	220mA±5%
Power tolerance	±5%
Current output tolerance	±5%
Dimming range	8%-100%
Dimmer	Triac dimmers
Short circuit protection	PASS
Over voltage protection	PASS
Over temperature protection	PASS
Withstand voltage	AC3750V

Fixture Compatibility

Rated Wattage	Electrical Classification	Ingress Protection	Operating Temp	Operating Humidity	Storage Temp
10W	II	IP20	-20°C~45°C	0~90%	-20°C~65°C

Spectral Distribution

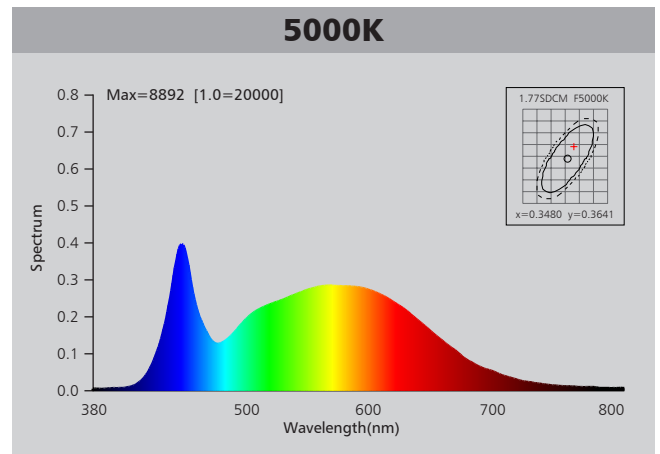
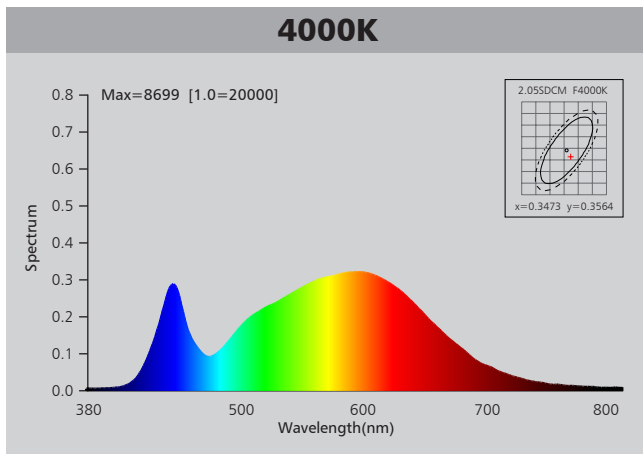
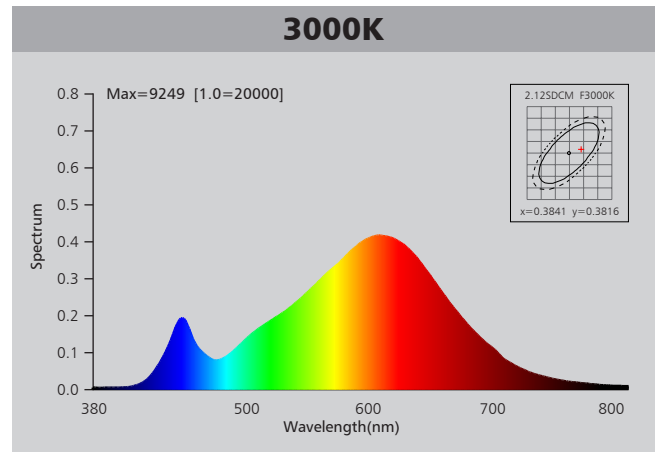
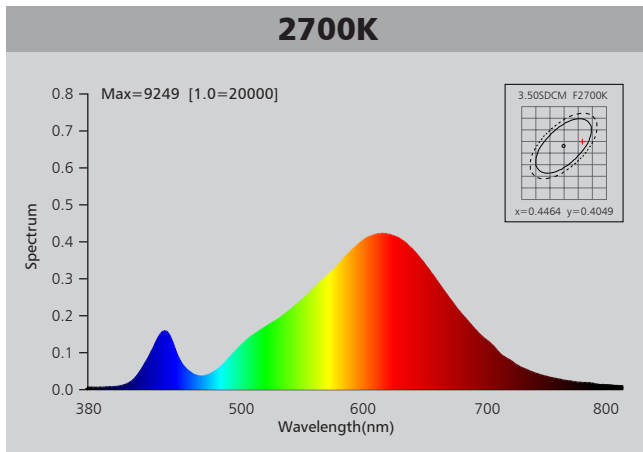

Photometric Diagram

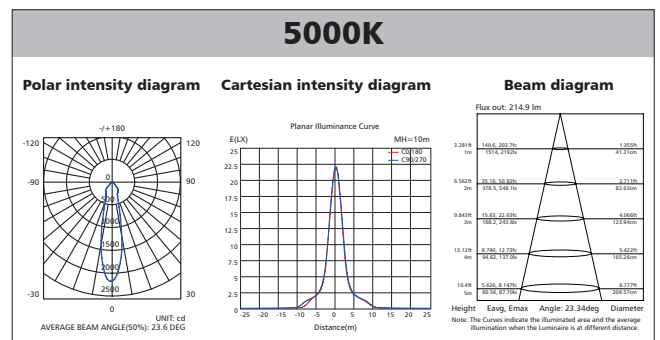
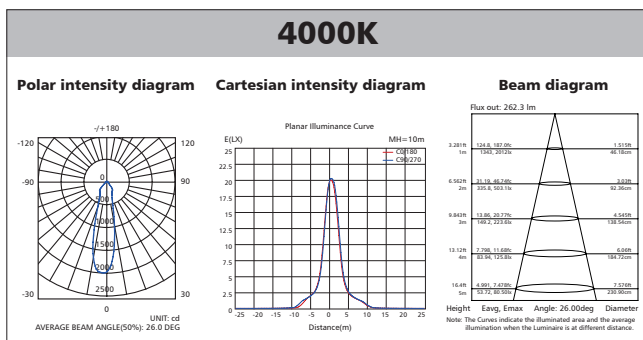
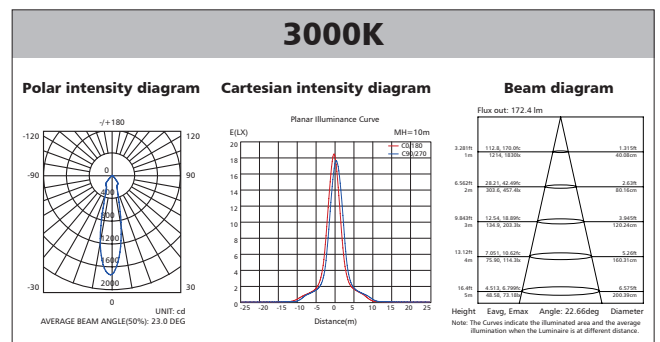
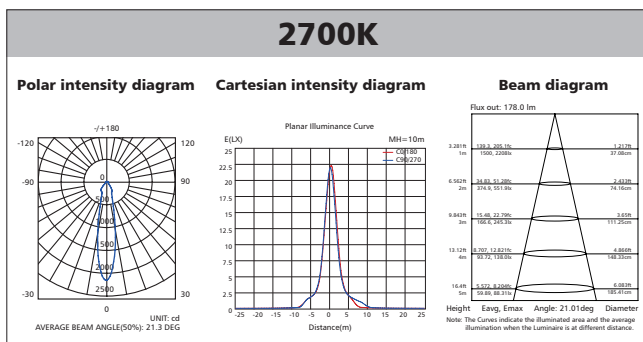

Polar Diagram Comparison

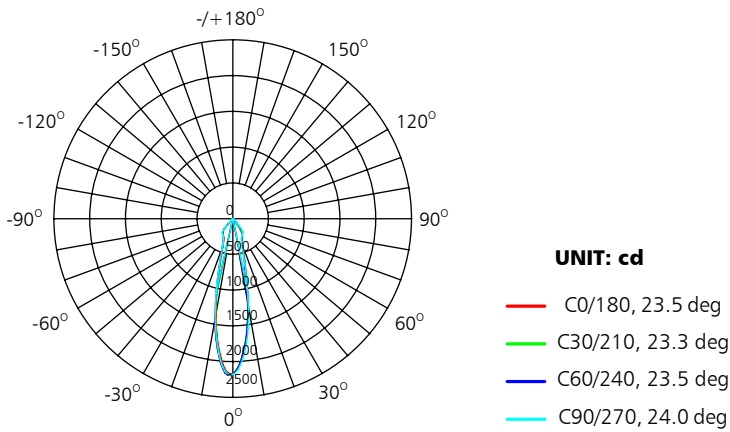

AVERAGE BEAM ANGLE (50%): 23.6DEG



Driver lifetime & LED light decay rate

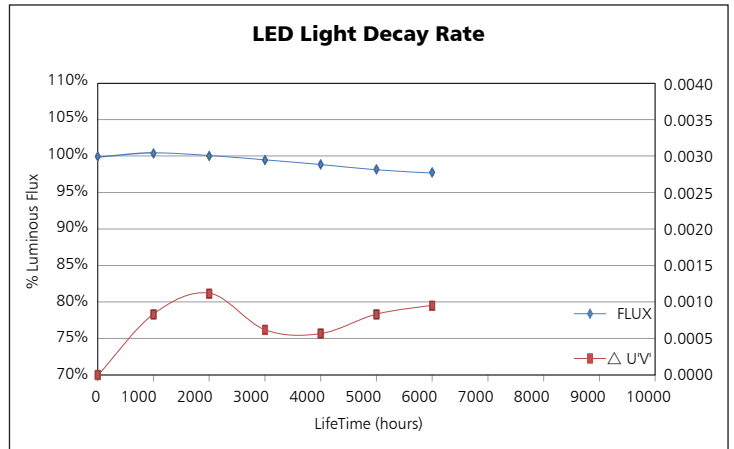
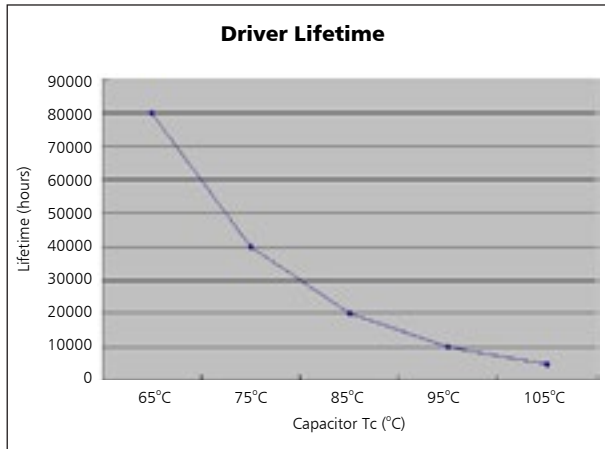

Temperature

- The testing is operated at 25°C
- The lifetime of capacitor, minimum of 5,000 hours if operated at 105°C, will be doubled whenever the temperature drops 10°C
- The highest withstand temperature of IC, MOS could be 120°C
- The highest withstand temperature of LED junction temperature is 150°C

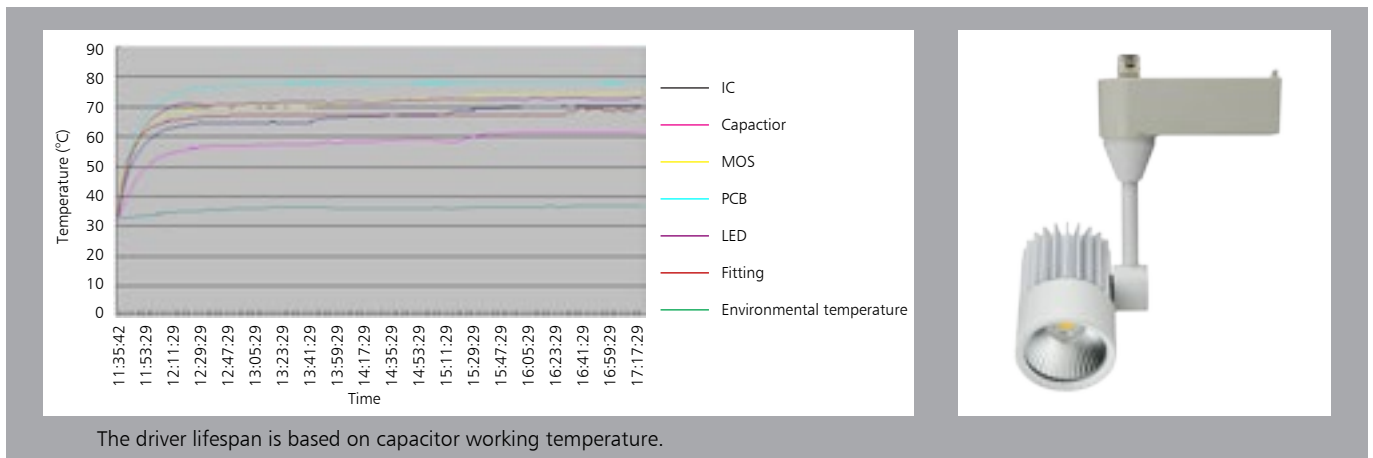

Installation

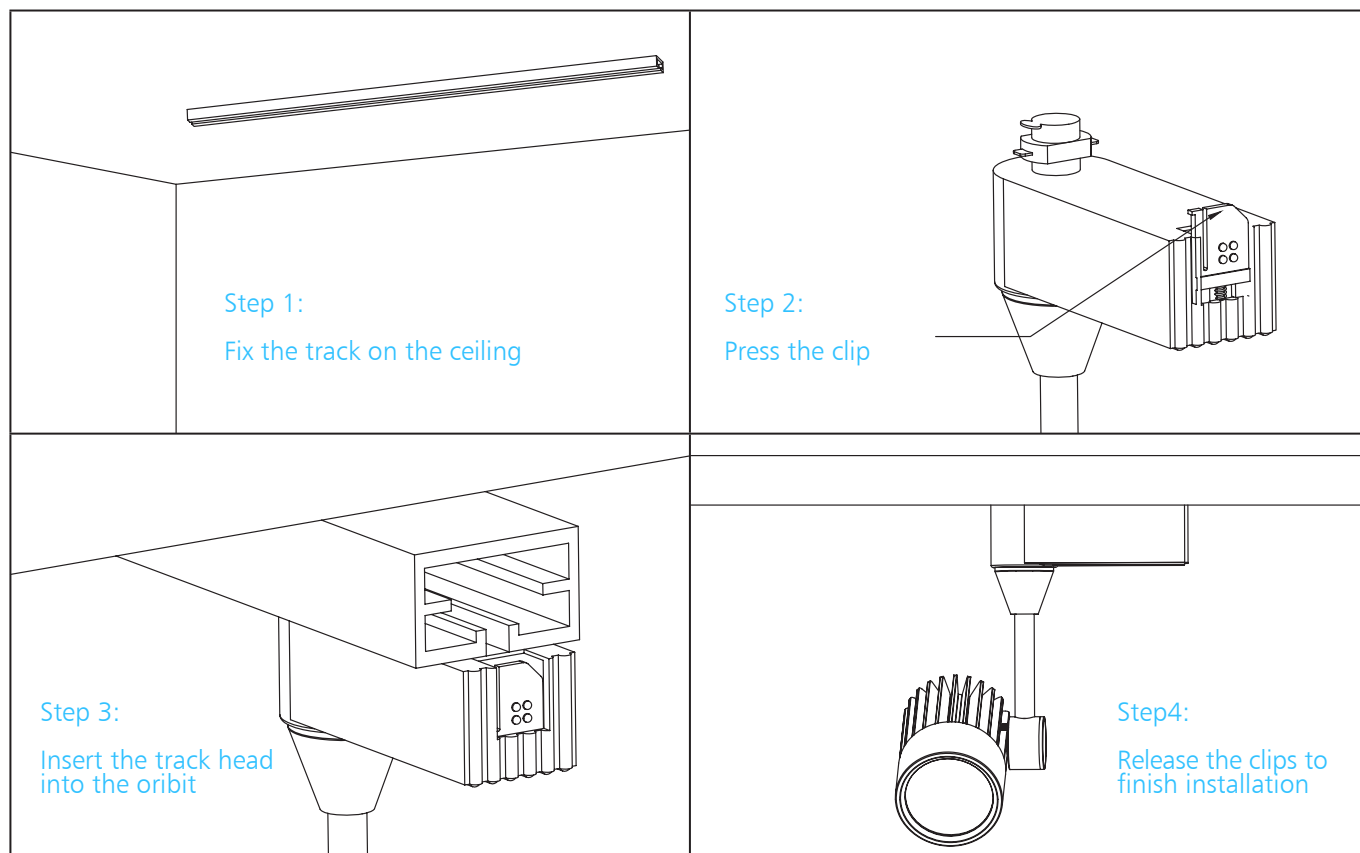

Packaging Information

	SIZE(CM)	N.W/pc (KGS)	G.W.(KGS)	Q'TY(PCS)
Carton	58*38*36.5	0.31	12.7	30

	CTNS	Q'TY(PCS)	VOLUME(CBM)
20" standard container	343	10290	28
40" standard container	687	20610	56

