

luzon
lighting™

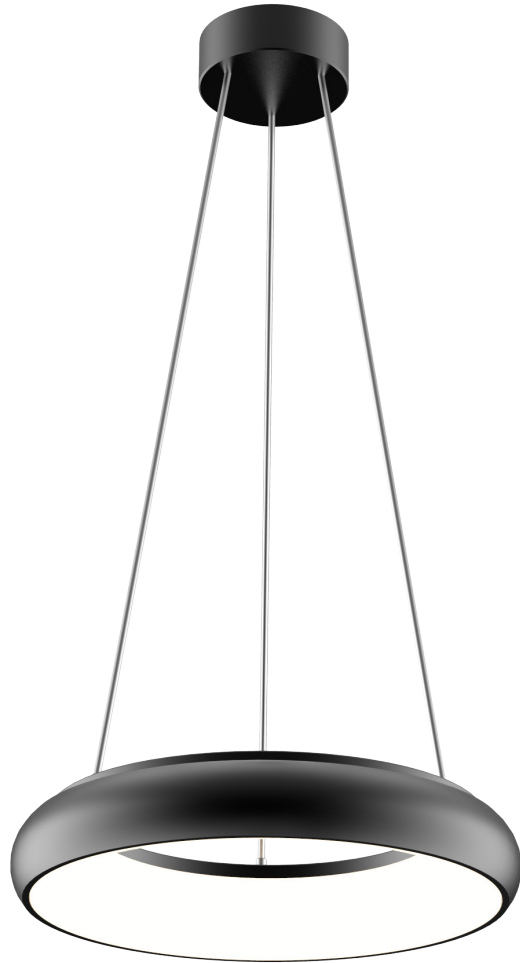

Technical Application

LED Ceiling light

LUZ-AL24B-12-25W

Introduction

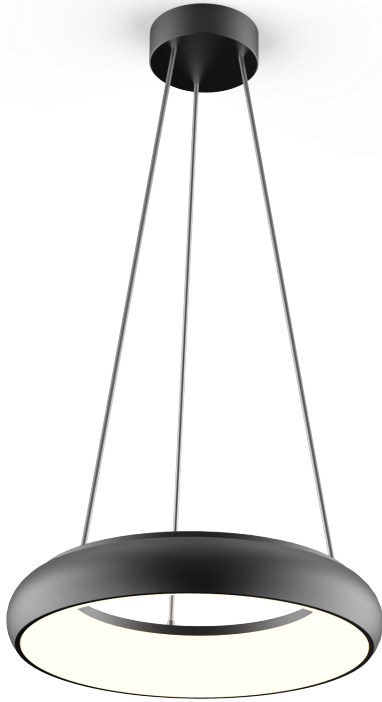

The hollow shape is full of creativity which brings vitality into ordinary lamp body and shows faultless performance, provides a strong sense of space.

The curved light direction emphasizes target object in a smooth and dramatic atmosphere, revealing an unexpected art inspiration design, which brings a comfortable visual experience.

By having an arc luminous surface, we break traditional design. The circular light output offers a magic 3D effect.

- Up to 70% energy saving compared to standard CFL
- Long lifetime of 40,000 hours
- Triac dim
- 120° wide beam angle
- CCT: 3000K 4000K
5000K 5700K
- No UV/IR light
- Environment friendly, without Mercury or any other hazardous substances

Application notes

- IP40 for indoor use only
- Professional electrician for installation only
- Switch off before installation
- Do not touch when in use
- Keep away from hot steam and corrosive gas

Application Areas

Suitable for leisure location, such as: home, hotel, library, restaurant, cafe shop etc.

Certificate

CE RoHS



Product Information

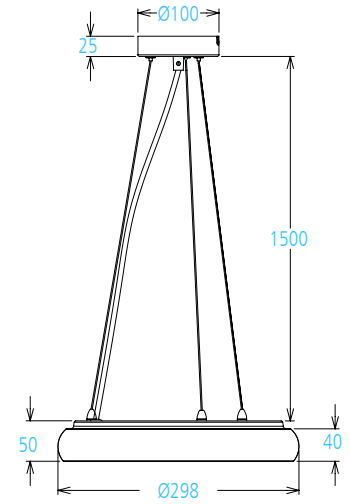

Technical Specifications

Model	Voltage	Power	Power Factor	Lumen (±5%)	Beam angle	CCT	Lifespan	CRI	Dimmable	Dimension
LUZ-AL24B-12-25W	AC100-277V	25W	≥0.9	1850	120°	3000K	40000h	≥80	No	Ø298*50mm
LUZ-AL24B-12-25W	AC100-277V	25W	≥0.9	2000	120°	4000K	40000h	≥80	No	Ø298*50mm
LUZ-AL24B-12-25W	AC100-277V	25W	≥0.9	1950	120°	5000K	40000h	≥80	No	Ø298*50mm
LUZ-AL24B-12-25W	AC100-277V	25W	≥0.9	1990	120°	5700K	40000h	≥80	No	Ø298*50mm
LUZ-AL24B-12-25W-D	AC230V	25W	≥0.9	1760	120°	3000K	40000h	≥80	Yes	Ø298*50mm
LUZ-AL24B-12-25W-D	AC230V	25W	≥0.9	1900	120°	4000K	40000h	≥80	Yes	Ø298*50mm
LUZ-AL24B-12-25W-D	AC230V	25W	≥0.9	1860	120°	5000K	40000h	≥80	Yes	Ø298*50mm
LUZ-AL24B-12-25W-D	AC230V	25W	≥0.9	1900	120°	5700K	40000h	≥80	Yes	Ø298*50mm

Driver data Sheet

Driver data	DIM	Non dim
Input rated Voltage	AC230V	AC100-277V
Frequency	50Hz	50/60Hz
Input Voltage	AC200-240V	AC90-305V
Efficiency	≥85%	≥88%
Total load Wattage	25W±5%	25W±5%
Power Factor	≥0.9	≥0.9
Rated input current	≤0.14A	≤0.28A
Full load output Voltage	DC65-78V	65-78V
Rated output current	300mA	310mA
Output current range	300mA±5%	310mA±5%
Power tolerance	±5%	±5%
Current output tolerance	±5%	±5%
Dimming range	8%-100%	—
Dimmer	Triac dimmers	—
Short circuit protection	PASS	PASS
Over voltage protection	PASS	PASS
Over temperature protection	PASS	PASS
Withstand voltage	AC1500V	AC1500V

Fixture Compatibility

Rated Wattage	Electrical Classification	Ingress Protection	Operating Temp	Operating Humidity	Storage Temp
25W	I	IP40	-20°C~45°C	0~90%	-20°C~65°C

Spectral Distribution

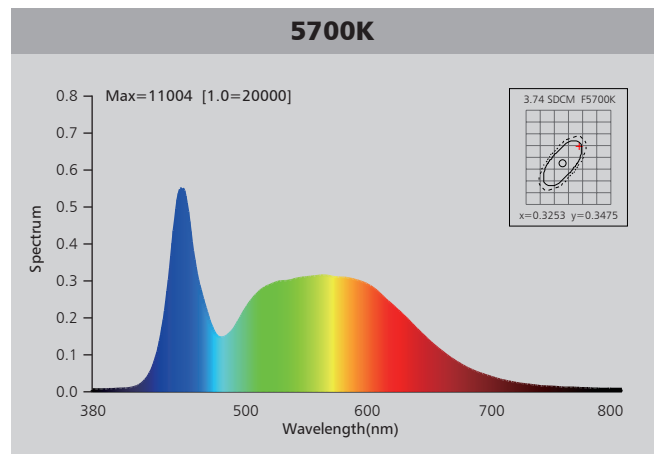
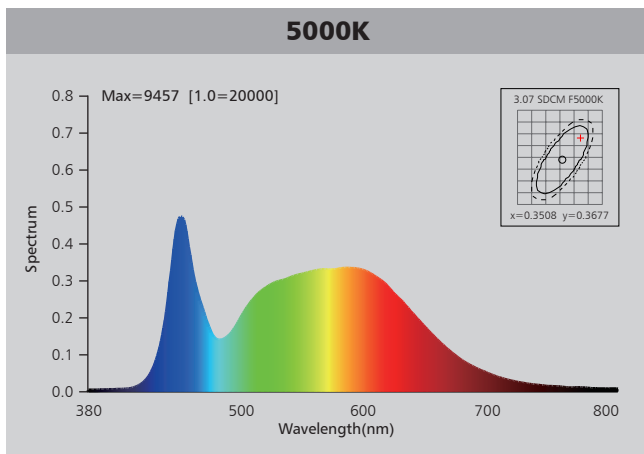
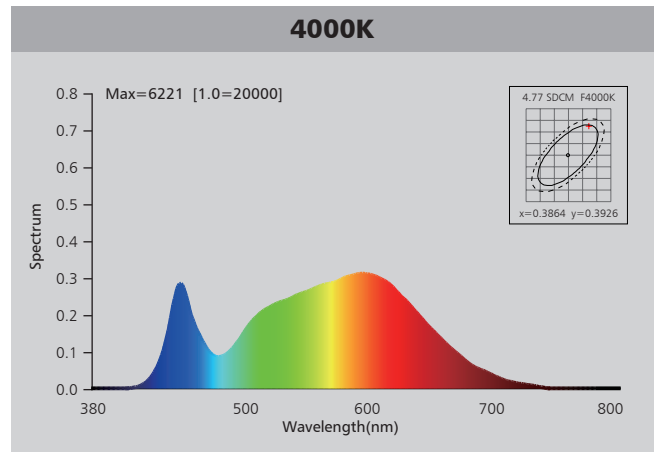
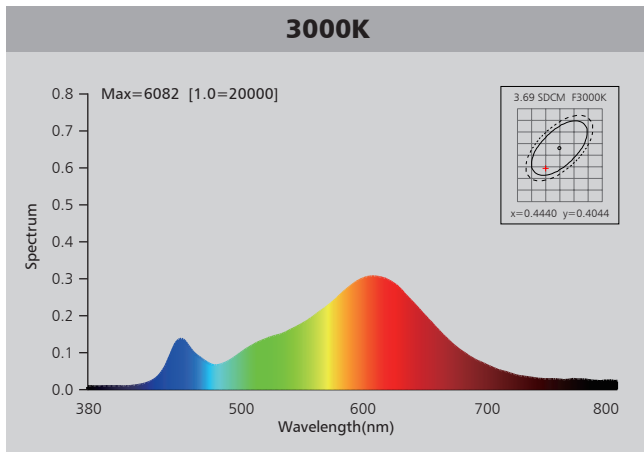

Photometric Diagram

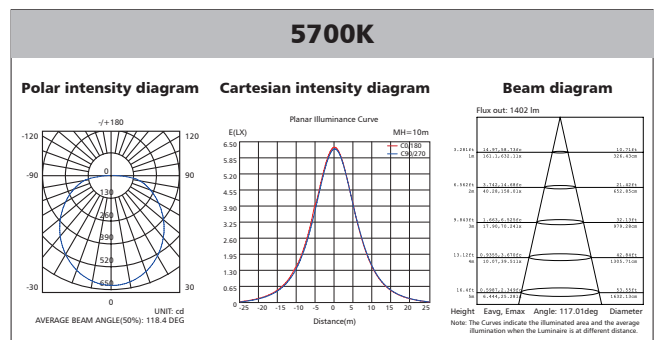
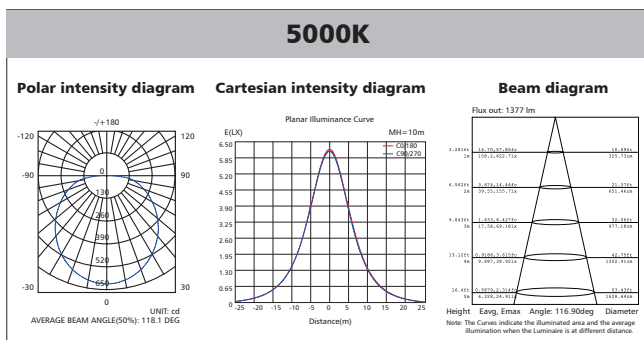
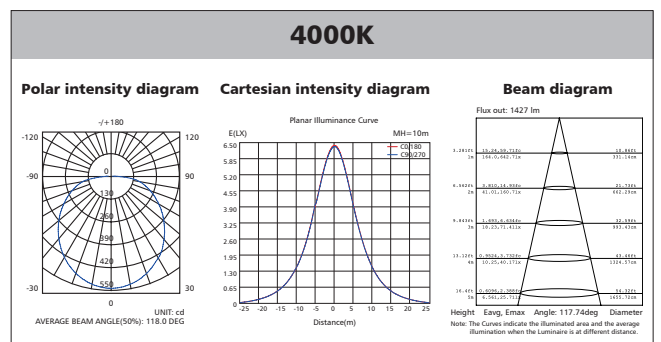
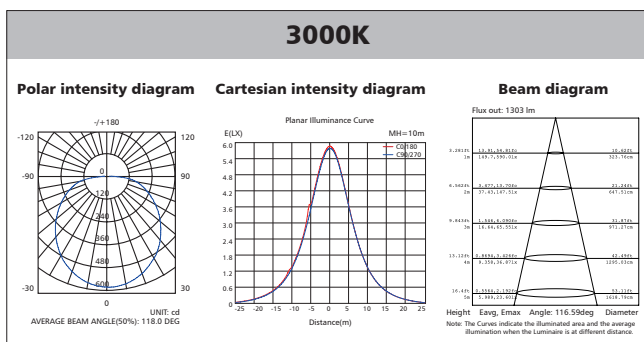

Polar Diagram Comparison

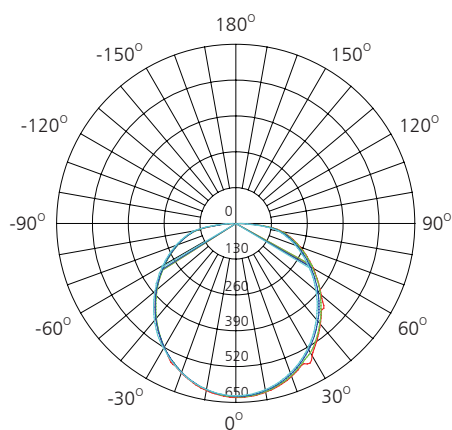

UNIT: cd

- C0/180, 118.7 deg
- C30/210, 118.8 deg
- C60/240, 118.0 deg
- C90/270, 118.0 deg

AVERAGE BEAM ANGLE (50%): 118.4DEG



Driver lifetime & LED light decay rate

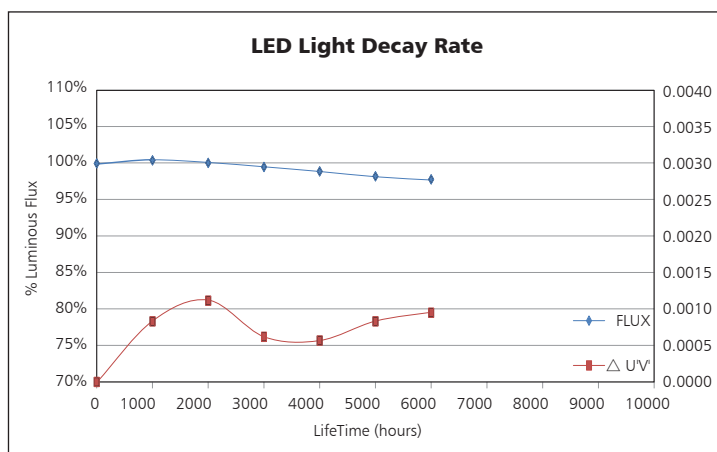
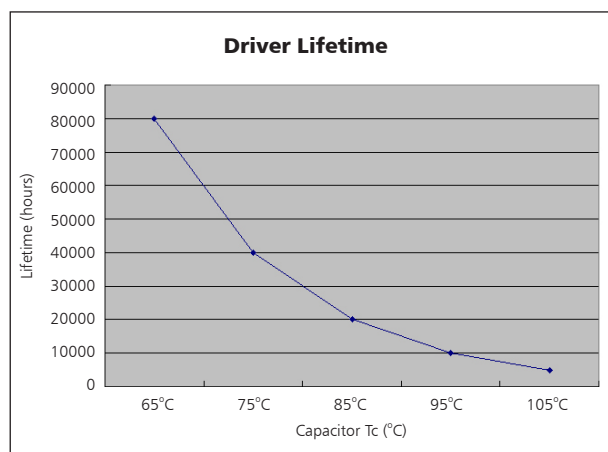

Temperature

- The testing is operated at 25°C
- The lifetime of capacitor, minimum of 5,000 hours if operated at 105°C, will be doubled whenever the temperature drops 10°C
- The highest withstand temperature of IC, MOS could be 120°C
- The highest withstand temperature of LED junction temperature is 150°C

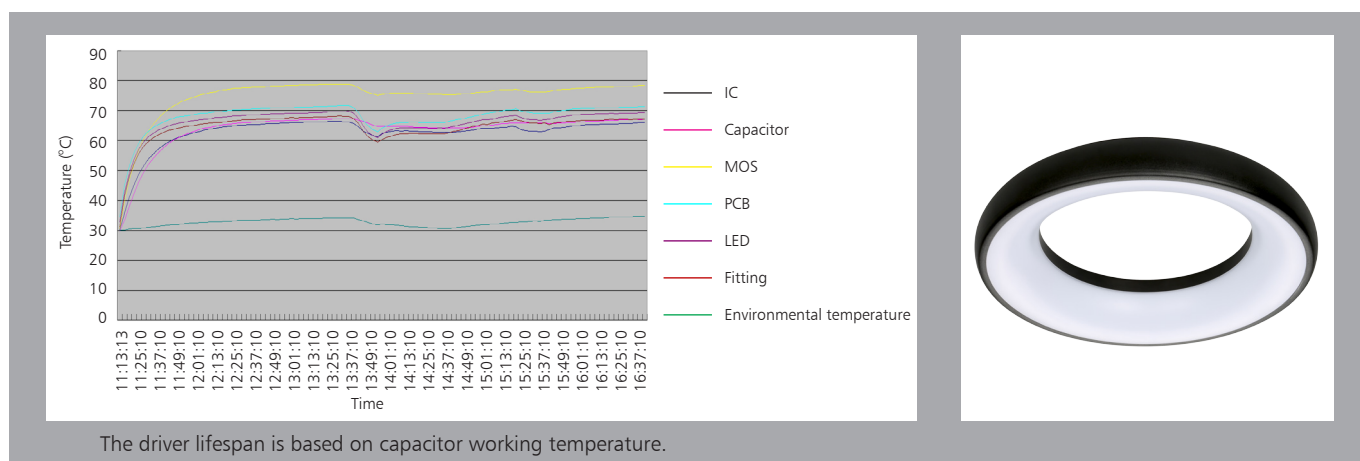

The driver lifespan is based on capacitor working temperature.

Installation

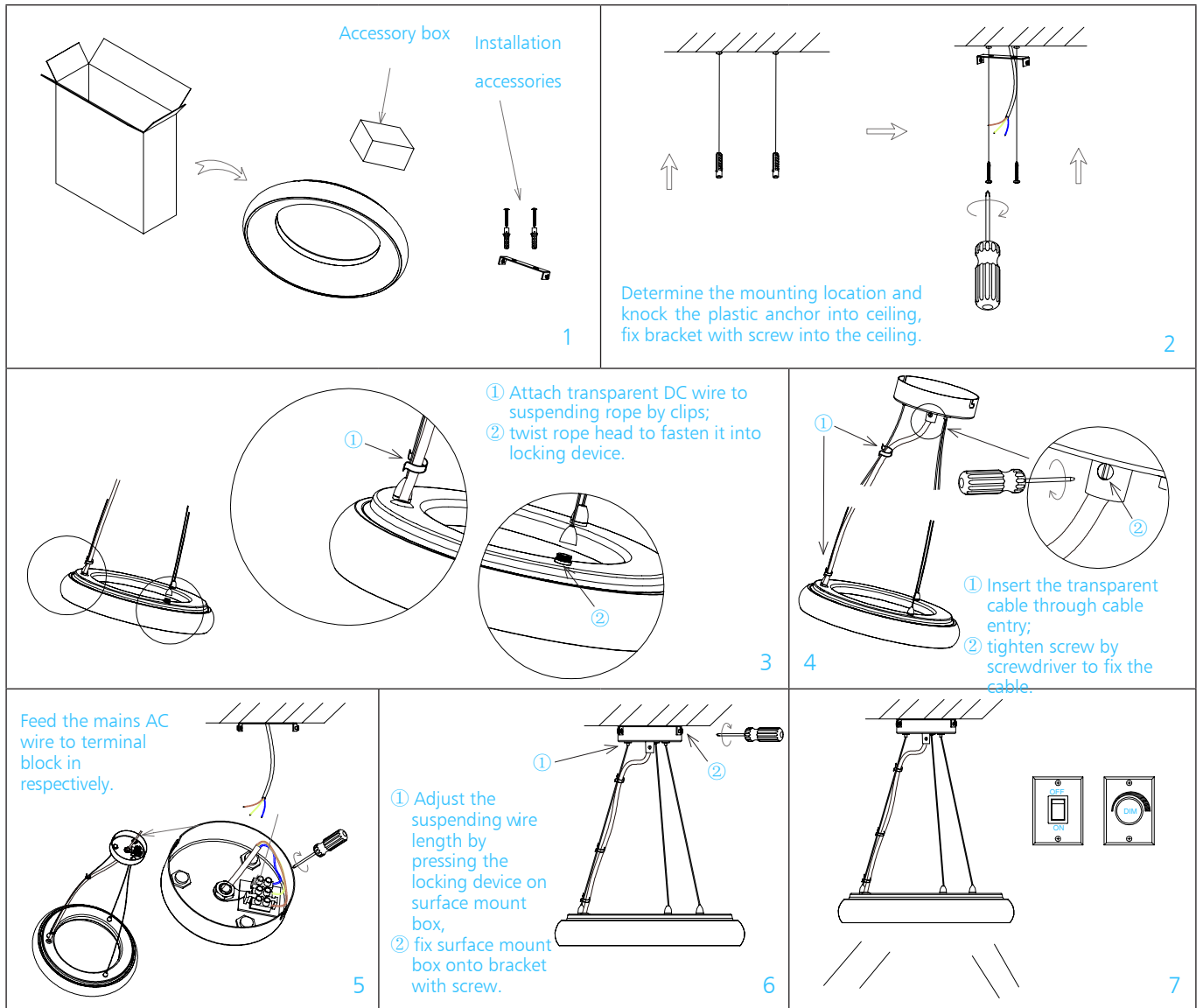

Packaging Information

	SIZE(CM)	N.W/pc (KGS)	G.W.(KGS)	Q'TY(PCs)
Carton	62.5*36.5*32.5	0.87	11.3	10

	CTNS	Q'TY(PCs)	VOLUME(CBM)
20" standard container	372	3720	28
40" standard container	744	7440	56

